

User Manual

Version 2.23.0

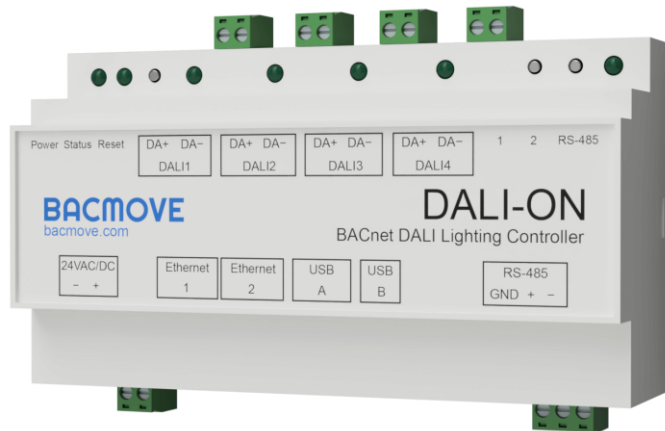

© 2024 TECHNOLOGIES BACMOVE INC. All rights reserved.

R20241205.0449

This information can be modified without notice.

Table of Contents

1 DALION	10
2 Introduction	11
2.1 Related documents	11
2.2 List of abbreviations	12
2.3 Specifications.....	12
2.4 Software Specifications.....	13
2.5 DALI Types Supported.....	13
2.6 BACnet Objects.....	14
2.7 BACnet Services	14
2.8 Ordering information	15
3 Hardware Installation	16
3.1 Warnings.....	16
3.1.1 RISK OF ELECTRIC SHOCK.....	16
3.2 Dimension.....	16
3.3 Connectors	17
3.4 Power	18
3.5 LEDs Indicators.....	18
3.5.1 Power supply.....	18
3.5.2 System status.....	18
3.5.3 DALI channels.....	19
3.5.4 RS-485.....	19
3.5.5 Ethernet	19
3.6 Installation	19
3.7 DALI wiring	20
4 Web User Interface	21
4.1 Responsive Web Interface.....	21
4.2 Login	21
4.3 Home.....	22
4.3.1 General Information.....	22
4.3.2 Interfaces Status	23
4.4 Settings.....	23
4.4.1 System.....	23

4.4.2	Date Time	24
4.4.3	Location	26
4.4.4	Network IP	26
4.4.5	BACnet/IP	27
4.4.6	DALI	30
4.4.7	BAS Communication Timeout	30
4.4.8	Backup / Restore	31
4.4.9	Reboot	31
4.4.10	Reset Commissioning	31
4.4.11	Factory Default	31
4.5	DALI Commissioning	31
4.5.1	Lamps	31
4.5.2	Lamp Parameters	32
4.5.3	Emergency Parameters	34
4.5.4	Colour Parameters	36
4.5.5	Colour Picker	36
4.5.6	Groups	39
4.5.7	Group Parameters	40
4.5.8	Groups 0-7 / 8-15	42
4.5.9	Scenes	43
4.5.10	Scenes Control	43
4.5.11	Scenes 0-7 / 8-15	44
4.5.12	Memory Bank	45
4.5.13	Inputs	45
4.5.14	Addition of DALI devices	56
4.5.15	Unassigned Devices	57
4.5.16	Assignment	57
4.6	Data	58
4.6.1	Data Points	58
4.6.2	Schedules	58
4.6.3	Room Light Control	62
4.6.4	Energy Usage Accumulated	67
4.7	Statistics	69
4.7.1	System Log	69
4.7.2	DALI	69

4.7.3	DALI protocol analyzer	70
4.7.4	BACnet/IP	71
4.7.5	BACnet Active COV Subscriptions	71
4.7.6	IP	71
4.7.7	TCP.....	71
4.7.8	UDP	72
4.7.9	ARP	72
4.7.10	ICMP	72
4.7.11	ARP Table.....	72
4.7.12	IP Memory.....	72
4.7.13	Ethernet	72
4.7.14	General.....	72
4.7.15	System Tasks.....	72
4.7.16	File System	72
5	BACnet Interface	73
5.1	Device Object	73
5.2	Network Port Object.....	75
5.3	Analog Output Object - Control of Lamp, Group, and Channel	76
5.3.1	Lamp.....	76
5.3.2	Group.....	79
5.3.3	Channel.....	81
5.4	Analog Input Object - Feedback of Lamp, Group, and Channel	94
5.4.1	Lamp, Group and Channel	94
5.5	Multi-State Output Object - Command Control of Lamp, Group and Channel	100
5.5.1	Lamp, Group and Channel	100
5.6	Analog Input Object - Light Sensor.....	104
5.6.1	Light Sensor.....	104
5.7	Binary Input Object - Occupancy Sensors	107
5.7.1	Occupancy Sensor	107
5.8	Binary Input Object - Buttons.....	109
5.8.1	Button	109
5.9	Multi-State Input Object - Scene Feedback of Group and Channel	111
5.9.1	Group and Channel.....	111
5.10	Loop Object - Room Light Control.....	113

5.10.1	Room Light Control	113
5.11	Analog Value - Lamp, Group, and Channel	122
5.11.1	Lamp, Group, Channel	122
5.12	Analog Value - Input Device	124
5.12.1	Input Device	124
5.13	Analog Value - Room Light Control	126
5.13.1	Room Light Control	127
5.14	Multi-State Value Object - Value of Lamp, Group and Channel	133
5.14.1	Lamp, Group and Channel	133
5.15	Multi-State Value Object - Room Light Control	135
5.15.1	Room Light Control	135
5.16	Multi-State Value Object - Commander.....	139
5.16.1	Commander	139
6	Room Light Control.....	141
6.1	Occupancy Sensors.....	141
6.2	Occupied Mode	141
6.3	Occupied Command	141
6.4	Unoccupied Command	141
6.5	Unoccupied Warning	141
6.6	Override Timeout.....	142
6.7	Ignore Time.....	142
6.8	Hold Time.....	142
6.9	Occupancy Process	142
6.10	Light Sensors	143
6.11	Setpoint.....	143
6.12	Daylight Harvesting.....	143
6.13	Multiple Lighting Zones	144
6.14	Demand Response	145
6.15	Schedules	145
6.16	Web Interface.....	145
6.16.1	Room Light Control	145
6.16.2	Room Light Control Configuration	145
6.16.3	Room Light Control States	145
6.17	BACnet Interface	146

7	Schedule.....	147
8	Commander.....	148
8.1	Specifications.....	148
8.2	Parameters.....	148
8.2.1	Name	148
8.2.2	Execute Count.....	149
8.2.3	Steps.....	149
9	USB Console.....	151
9.1	USB Connector.....	151
9.2	Serial Console Settings	152
9.3	Commands General	152
9.3.1	help	152
9.3.2	version	152
9.3.3	reboot.....	152
9.3.4	factorydefault.....	152
9.3.5	date.....	152
9.3.6	ping	152
9.3.7	status	152
9.3.8	ip [addr a].....	152
9.4	Commands Statistics.....	152
9.4.1	stip	152
9.4.2	stbacnetip.....	152
9.4.3	stdali	152
9.4.4	stdalianalyzer channel.....	153
9.4.5	sttcp	153
9.4.6	studp	153
9.4.7	starp.....	153
9.4.8	sticmp	153
9.4.9	starptable	153
9.4.10	steth	153
9.4.11	logread.....	153
9.5	Commands System Settings	153
9.5.1	setsystem.....	153
9.6	Commands IP Settings	153

9.6.1	setip	153
9.7	Commands BACnet/IP Settings	154
9.7.1	setbacnetip.....	154
10	DALION Tool	156
10.1	Overview	156
10.1.1	Installation.....	156
10.2	Menu.....	157
10.2.1	Home	157
10.2.2	About	157
10.3	Sites	157
10.3.1	Folder.....	157
10.3.2	Device.....	157
10.4	Download Backup	158
10.4.1	Preparations.....	158
10.4.2	Download.....	158
10.5	Restore Backup.....	158
10.5.1	Preparations.....	159
10.5.2	Restore	159
10.6	Firmware Upgrade.....	159
10.6.1	Warnings.....	160
10.6.2	Preparations.....	160
10.6.3	Upgrade	160
10.7	Pre-Commissioning	160
11	Remote CLI Tool	162
11.1	Overview	162
11.2	Commands.....	162
11.2.1	help	162
11.2.2	version	162
11.2.3	ip.....	162
11.2.4	channel	162
11.2.5	channelcsvfile.....	162
11.2.6	channelgroupscsvfile.....	163
11.2.7	channelinputscsvfile	163
11.2.8	action	163

11.2.9	firmwarefile.....	163
11.2.10	backupfileouttype	164
11.2.11	backupconfig.....	164
11.2.12	backupfileout.....	164
11.2.13	backupfilein	164
11.3	Channel Lamps CSV File Format	164
11.3.1	First line	165
11.3.2	Second line	165
11.3.3	Third line	165
11.3.4	Columns.....	165
11.4	Channel Groups CSV File Format	168
11.4.1	First line	168
11.4.2	Second line	168
11.4.3	Third line	169
11.4.4	Columns.....	169
11.5	Channel Inputs CSV File Format	169
11.5.1	First line	169
11.5.2	Second line	169
11.5.3	Third line	170
11.5.4	Columns.....	170
11.6	Example of command	172
11.6.1	DALI Pre-comminising configuration	172
11.6.2	Download Backup	173
11.6.3	Upload Backup.....	173
11.6.4	Firmware Upgrade	173
12	API.....	175
12.1	Overview	175
12.2	Requests.....	175
12.2.1	Sets lamp, group or channel light intensity	175
12.2.2	Get the list of lamps and control devices	176
12.2.3	Get lamp information	180
12.2.4	Set lamp information	189
12.2.5	Get groups	190
12.2.6	Get scenes.....	194

12.2.7	Set scenes	196
12.2.8	Recall, store and delete scenes for groups or channel	197
12.2.9	Set lamp, group or channel DT8 colour	197

1 DALION

The DALION can be used to automatically perform DALI room control with occupancy, daylight harvesting, demand response, and more. The gateway functionality allows bidirectional communication between DALI (Digital Addressable Lighting Interface, IEC 62386) networks and BACnet systems. It integrates many functionalities to ease the installation of DALI lighting on the BACnet network.

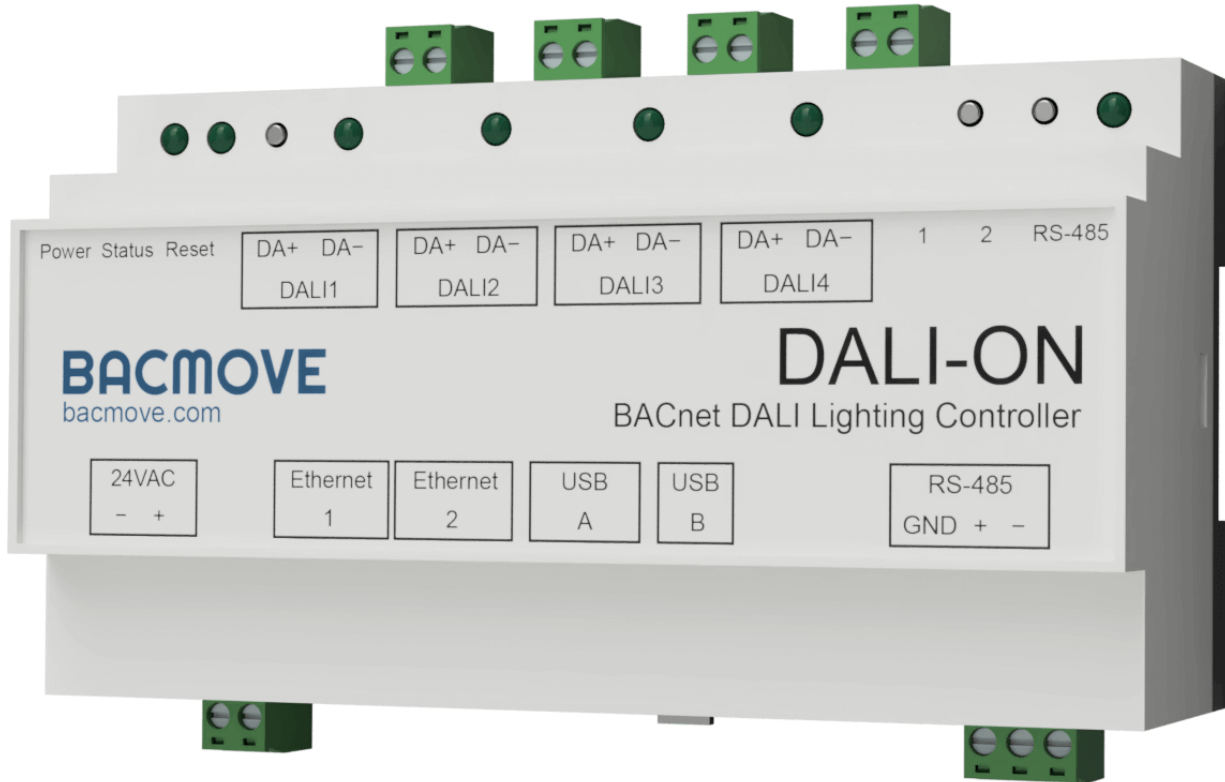

2 Introduction

The DALION controller allows bidirectional communication between DALI devices (Digital Addressable Lighting Interface, IEC 62386) and BACnet systems. It integrates many functionalities to ease the installation of DALI systems with BACnet networks.

The DALION-4 is equipped with four independent DALI channels. DALION-4 can control up to 256 DALI devices. The DALION-1 is equipped with one DALI channel. DALION-1 can control up to 64 DALI devices. This is 64 devices with 16 groups and 16 scenes per channel. Each channel requires a separated DALI power supply.

It can also integrate up to 32 DALI-2 input devices (control devices) per DALI channel. Light sensors, occupancy sensors and buttons can be configured via the web interface.

The BACnet/IP protocol uses the Ethernet interface to communicate. DALI's channels, groups, lamps, scenes, light sensors, occupancy sensors and buttons are accessible through BACnet standard objects such as Analog Output, Analog Input, Multi-State Output, etc.

The DALION commissioning and configurations are performed via an integrated and responsive web interface. The user interface is accessible from a modern internet browser on several electronic devices such as computers, iPhone, Android and tablets. Therefore, no additional software installation is required.

2.1 Related documents

Available from the website:

- DALION datasheet
- PICS

2.2 List of abbreviations

Abbreviation	Description
100BASE-T	100 Mbps Ethernet with RJ-45 connector
BACnet	Building Automation and Control Network
BBMD	BACnet Broadcast Management Device
BDT	BACnet Broadcast Distribution Table
COV	BACnet Change of Value service
DALI	Digital Addressable Lighting Interface, IEC 62386
DHCP	Dynamic Host Configuration Protocol
DiiA	Digital Illumination Interface Alliance
DNS	Domain Name Server
IP	Internet Protocol
JSON	JavaScript Object Notation
LAN	Local Area Network
MAC	Medium Access Control
NaN	Not a Number
UI	User Interface

2.3 Specifications

Model	DALION-4, DALION-1
Power supply	24 VAC \pm 10%, 50-60 Hz or 24 VDC \pm 10%
Power consumption	200 mA typical
DALI channels	4 (DALION-4), 1 (DALION-1), low voltage DALI bus, external power supply
Ethernet interface	2, RJ45 Port, 100BASE-T, BACnet/IP, HTTP
USB console port	Mini Type-B USB 2.0, isolated
Button	User button 1, user button 2, reset button
LED Indication	Power supply, system status, DALI channels, Ethernet
Firmware	Upgradable firmware
Operating temperature	0 °C to 45 °C (32 °F to 113 °F)
Operating humidity	5 to 90%, no condensation
Dimension	157 x 86 x 59 mm, 6.181" x 3.386" x 2.323" (L x W x H)
Weight	220 g
Fixation	DIN rail

Enclosure material	Light gray, UL 94 V-0
Protection	IP20

2.4 Software Specifications

Name	Description
Protocols	BACnet/IP, DALI, HTTP
DALI Lamps	64 per DALI channel
DALI-2 Inputs	32 per DALI channel (*)
Schedules	4 (DALION-4), 1 (DALION-1), weekly schedules with 6 events per day, astronomical time clock
Room Light Control	16 per channel, with each up to 1 light sensor, 8 occupancy sensors and 4 outputs
COV Subscriptions	580
COV Subscriptions Addresses	8

(*) For light sensors and occupancy sensors, only the first instance of a control device is available. For buttons all 32 possible instances of a control device are available.

2.5 DALI Types Supported

List of supported DALI (IEC 62386) device types.

Name	Type	Note
Fluorescent lamps – 201	device type 0	
Self-contained emergency lighting – 202	device type 1	
D.C. voltage – 206	device type 5	
LED modules – 207	device type 6	
Switching function – 208	device type 7	
Colour control – 209	device type 8	xy-coordinate, colour temperature Tc, primary N and RGBWAF
Input devices – Push buttons	301	
Input devices – Occupancy sensor	303	
Input devices – Light sensor	304	

2.6 BACnet Objects

List of available BACnet objects.

Name	Usage
Device	
Network Port	
Analog Input	Feedback for the lamps, groups and channels. Value of light sensors
Analog Output	Commands for the lamps, groups and channels
Analog Value	Parameters for the lamps, groups, channels, input devices and Room Light Control
Multi-state Output	Scenes and commands controllers
Multi-state Input	Scene feedback of group and channel
Multi-state Value	Parameters for the lamps, groups, channels and Room Light Control
Binary Input	Occupancy sensors and button value
Loop	Room Light Control

2.7 BACnet Services

List of available BACnet services.

BACnet Service	Initiate	Execute
I-Am	x	
Who-Has	x	
Who-Is	x	
DeviceCommunicationControl		x
ReinitializeDevice		x
ReadProperty		x
ReadPropertyMultiple		x
WriteProperty		x
WritePropertyMultiple		x
SubscribeCOV		x
ConfirmedCOVNotification	x	
UnconfirmedCOVNotification	x	
TimeSynchronization		x
UTCTimeSynchronization		x

2.8 Ordering information

Model Number	Model Description
DALION-4	DALI - BACnet/IP, DALION controller with 4 DALI channels
DALION-1	DALI - BACnet/IP, DALION controller with 1 DALI channel

3 Hardware Installation

3.1 Warnings

3.1.1 RISK OF ELECTRIC SHOCK



- THE CONTROLLER MUST ONLY BE INSTALLED BY QUALIFIED PROFESSIONALS IN ACCORDANCE WITH APPLICABLE NATIONAL AND LOCAL LAWS AND REGULATIONS.
- FOR INDOOR USE ONLY.
- DO NOT CONNECT THE MAINS/LINE VOLTAGE TO ANY CONNECTOR ON THE CONTROLLER.
- THE CONTROLLER IS INTENDED TO BE INSTALLED INSIDE A CONTROL PANEL OR A BOX AND MUST NOT BE ACCESSIBLE FROM THE OUTSIDE.
- DO NOT COVER THE CONTROLLER WITH OTHER MATERIALS DURING USE.
- KEEP WATER AND OTHER LIQUIDS AWAY FROM THE CONTROLLER.

3.2 Dimension

The dimensions are 157 x 86 x 59 mm, 6.181" x 3.386" x 2.323" (L x W x H).

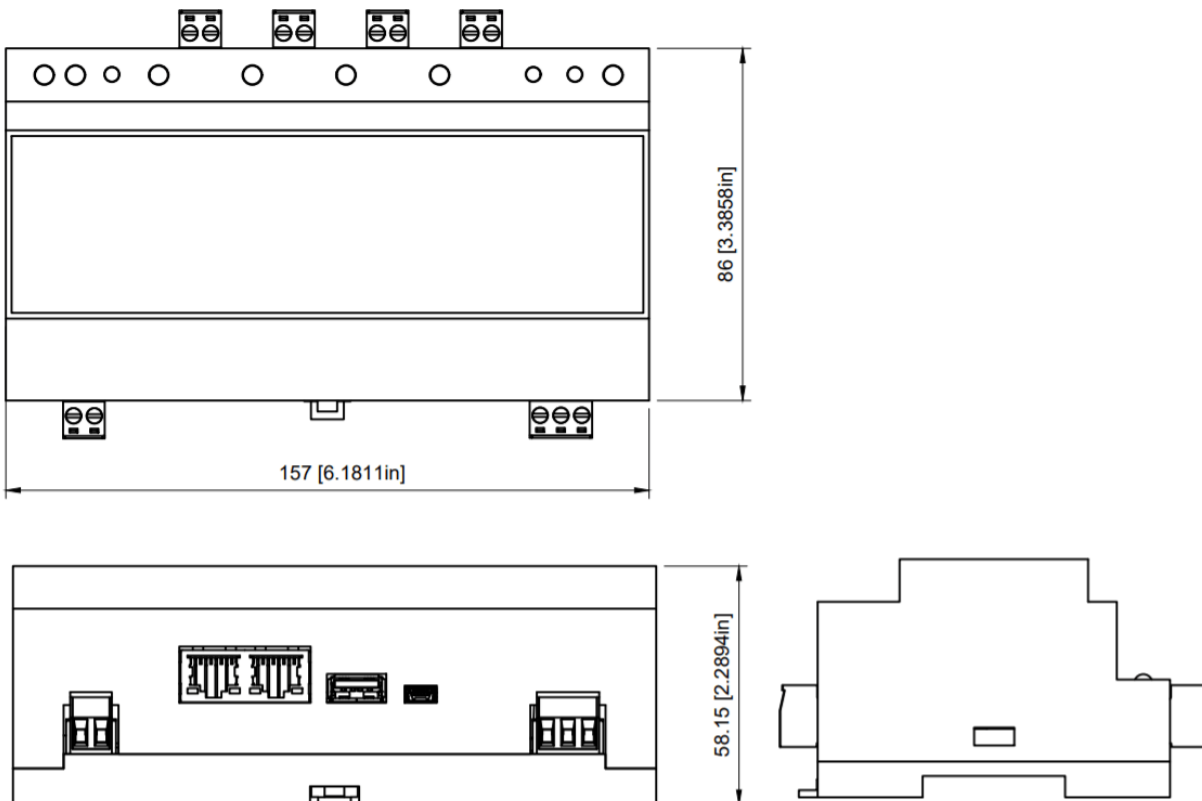

3.3 Connectors

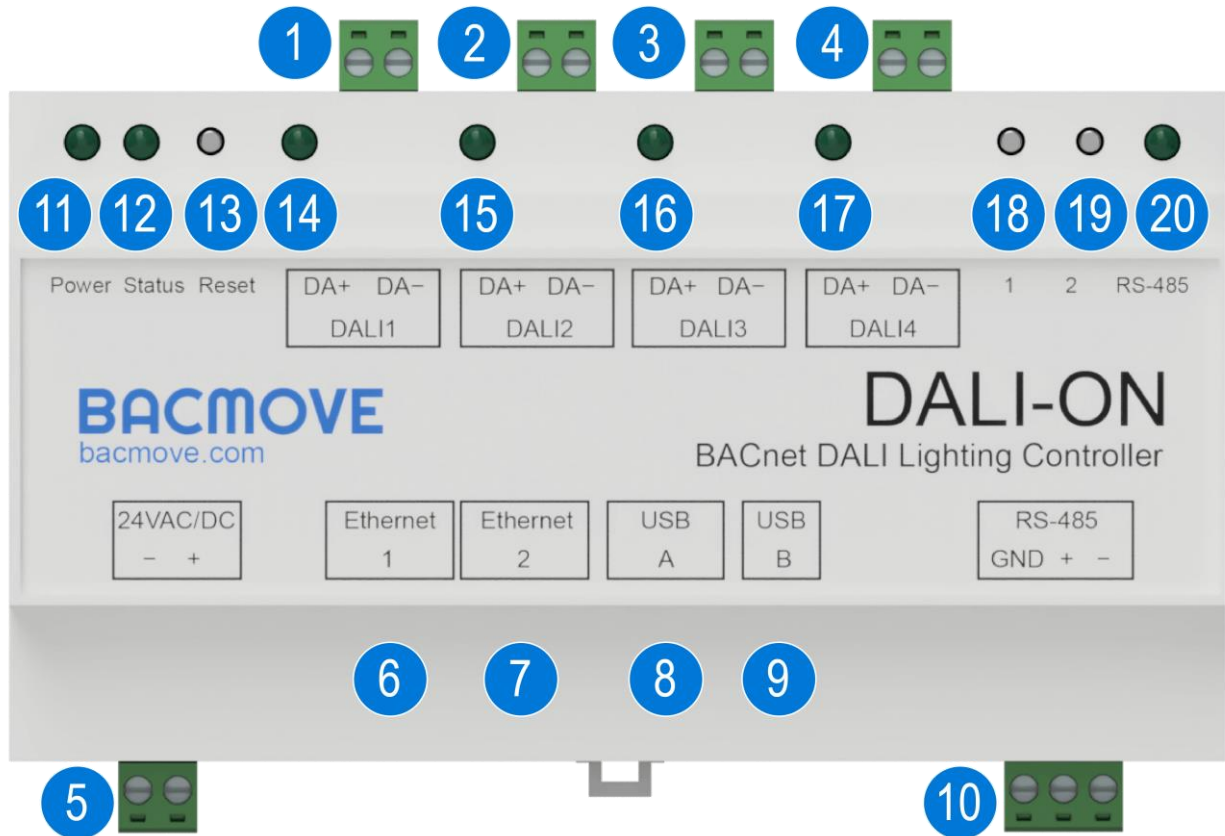

1. DALI Channel 1 connector
2 position pluggable terminal blocks header of 5.08 mm [0.200"].
2. *DALI Channel 2 connector
2 position pluggable terminal blocks header of 5.08 mm [0.200"].
3. *DALI Channel 3 connector
2 position pluggable terminal blocks header of 5.08 mm [0.200"].
4. *DALI Channel 4 connector
2 position pluggable terminal blocks header of 5.08 mm [0.200"].
5. 24 VAC/DC power supply connector
2 position pluggable terminal blocks header of 5.08 mm [0.200"].
6. First Ethernet connector
RJ45 connector. Connect the LAN Ethernet network to this port.
7. Second Ethernet connector
RJ45 connector. Switch port with the first Ethernet connector.
8. N/A

9. USB device connector
USB 2.0 - Mini-B connector. For the USB console.
10. N/A
11. Power LED indicator
This LED indicator is on when the DALION is powered.
12. Status LED indicator
This LED indicator blinks to indicate the status of the DALION.
13. Reset IP button
Operate only with electrically insulated tools. Pressing this button for four (4) seconds will reset the IP configurations to the factory default value.
14. DALI Channel 1 LED indicator
Activity LED indicator for the DALI channel 1.
15. *DALI Channel 2 LED indicator Activity LED indicator for the DALI channel 2.
16. *DALI Channel 3 LED indicator Activity LED indicator for the DALI channel 3.
17. *DALI Channel 4 LED indicator Activity LED indicator for the DALI channel 4.
18. Button 1
Pressing this button sends 100% to all lamps on all DALI channels.
19. Button 2
Pressing this button sends 0% to all lamps on all DALI channels.
20. N/A

*The DALI Channel 2, 3 and 4 are only available on the 4 DALI channels model.

3.4 Power

The DALION must be powered by a 24 VAC or 24 DC power source.

The supply circuit inside the DALION uses a half-wave rectifier. It can therefore be supplied with the same AC power supply as other devices using a half-wave rectifier. The power supply must be separated from devices using full-wave rectifiers. DC power supply can be shared with other devices.

3.5 LEDs Indicators

3.5.1 Power supply

On when the DALION is powered up.

3.5.2 System status

Blink at an interval of 500 milliseconds to indicate that the DALION is operating properly.

3.5.3 DALI channels

Off when there is no DALI power supply. Lit when there is a DALI power supply. Blinks when DALI packets are received.

3.5.4 RS-485

Blinks when transmitting packets.

3.5.5 Ethernet

3.5.5.1 *Green*

Indicates the Ethernet link and blink when there is network activity.

3.5.5.2 *Yellow*

Indicates the Ethernet speed. LED indicator is on for 100 Mbps, LED indicator is off for 10 Mbps.

3.6 Installation

Installation steps:

- Install the DALION with the DIN rail fixation.
- Connect the DALION to the DALI channel bus. An external DALI power supply must be present on the bus.
- Connect the DALION to the LAN Ethernet network.
- Connect the DALION to a 24 VAC transformer Class 2 or a 24 VDC power supply.

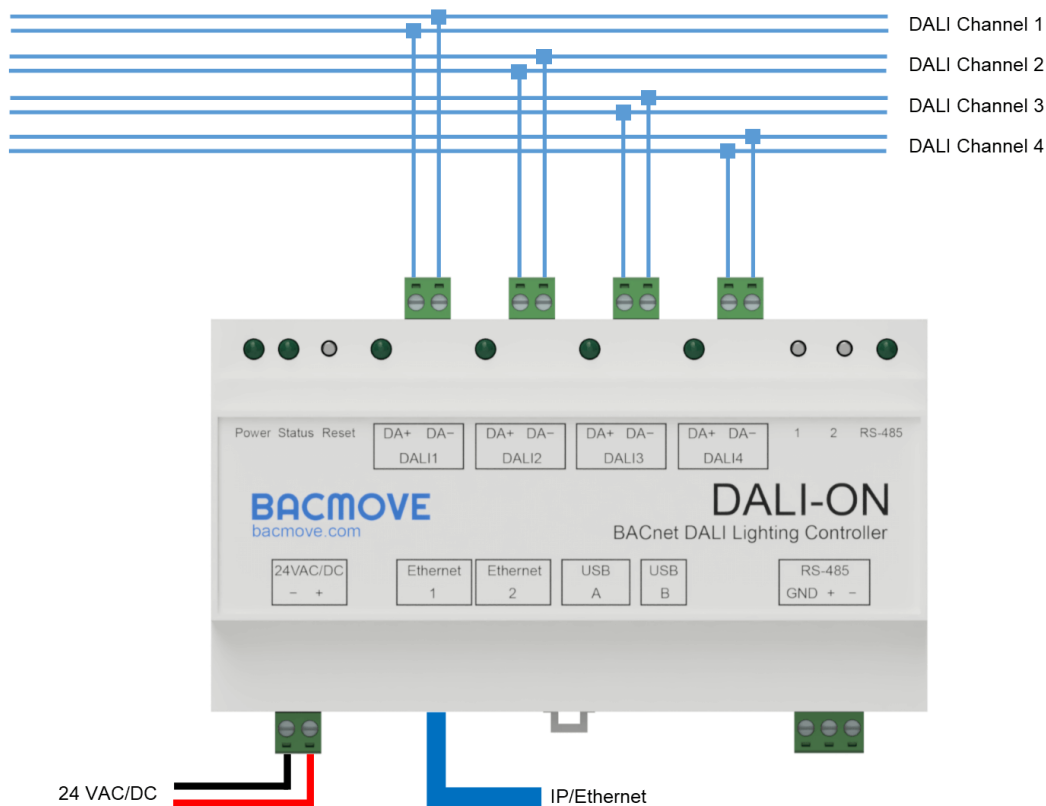

3.7 DALI wiring

The bus wiring must be connected in a star topology, a linear topology or a mixture of the two. Wiring must not be carried out in a ring structure. The two wires that serve as the bus must be located in the same cable or cable conduit. In the cable or cable conduit, the two wires must be side by side to avoid unintentional coupling to other signals.

It is recommended to test the integrity of the DALI wiring. With a multimeter verify that there is no main AC voltage on the DALI wires. DALI devices with no protection will normally be destroyed by the main AC voltage.

4 Web User Interface

The web user interface allows modifying system settings as well as performing the DALI devices commissioning.

4.1 Responsive Web Interface

The web user interface adapts to all screen sizes.



To simplify documentation, the following sections show only screenshots on a desktop computer.

4.2 Login

The first page visible when accessing the DALION is the login page.

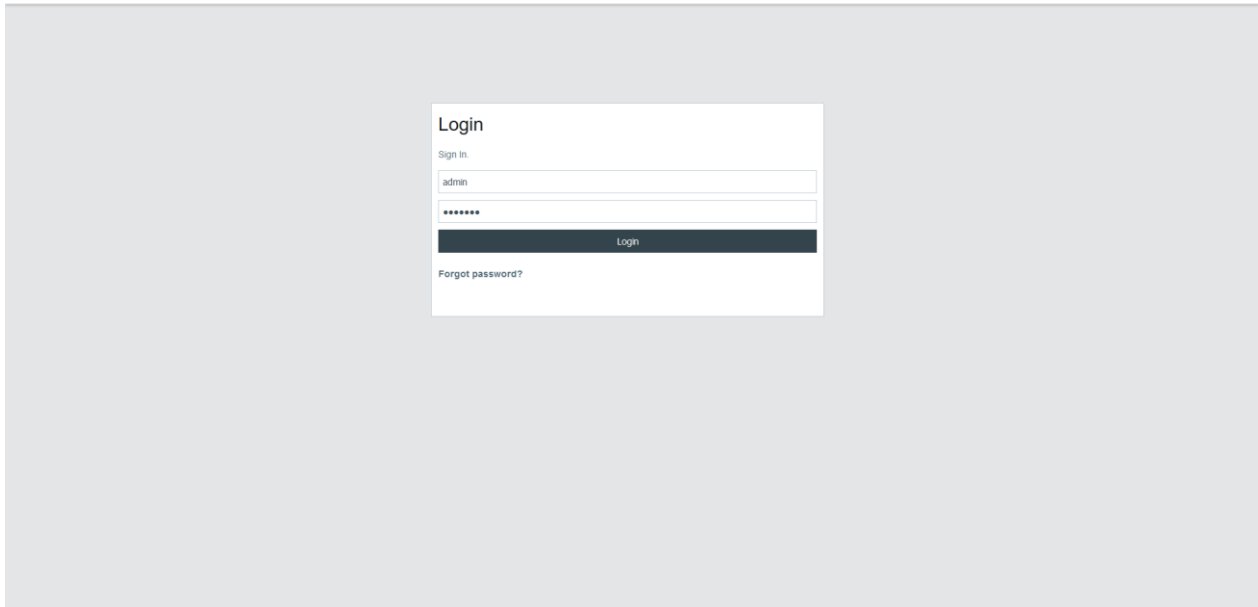

The default login details are as follows.

Username	Password
admin	DALION

If the password or username is lost, it can be recovered through the USB console.

4.3 Home

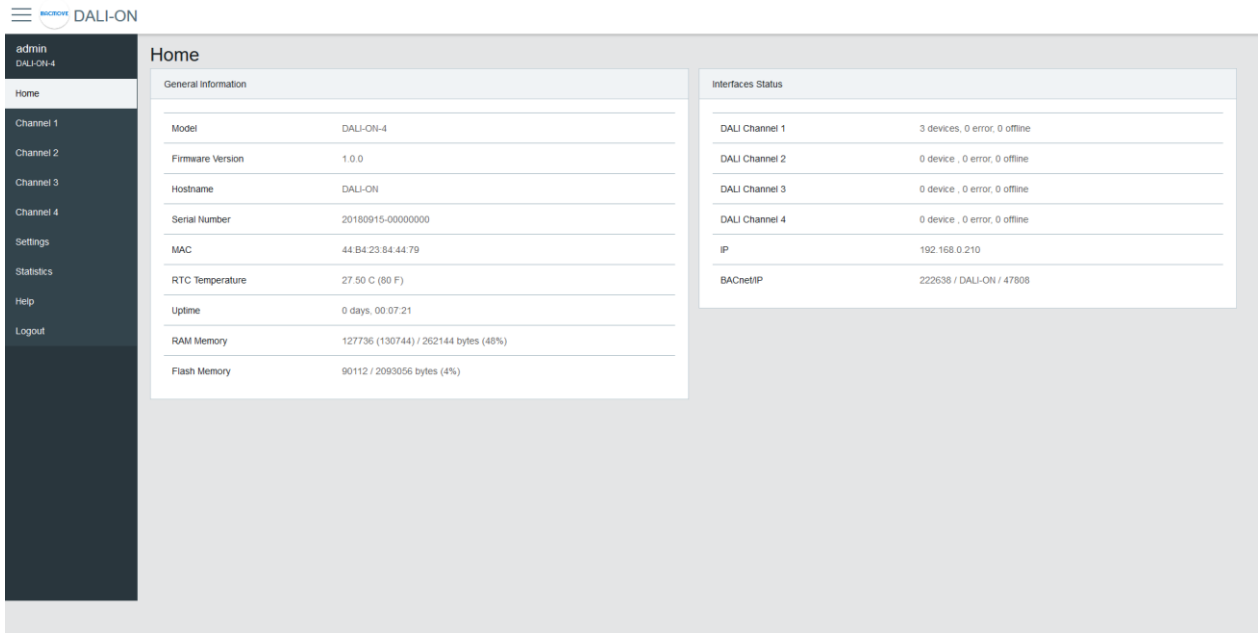

4.3.1 General Information

This section displays some general information about the system.

Name	Description
Model	Model name
Firmware Version	Firmware version
Build Date	Date of the firmware build
Hostname	Hostname of the controller
Serial Number	Serial Number
MAC	Ethernet MAC address
RTC Temperature	Current temperature of the controller
Uptime	Time since the last boot of the controller
RAM Memory	Usage of the volatile memory
Flash Memory	Usage of the non-volatile memory

4.3.2 Interfaces Status

This section displays the status of the network interfaces.

Name	Description
DALI Channel	Status of the DALI channel
IP	Status of the IP network
BACnet/IP	Status of the BACnet/IP interface

4.4 Settings

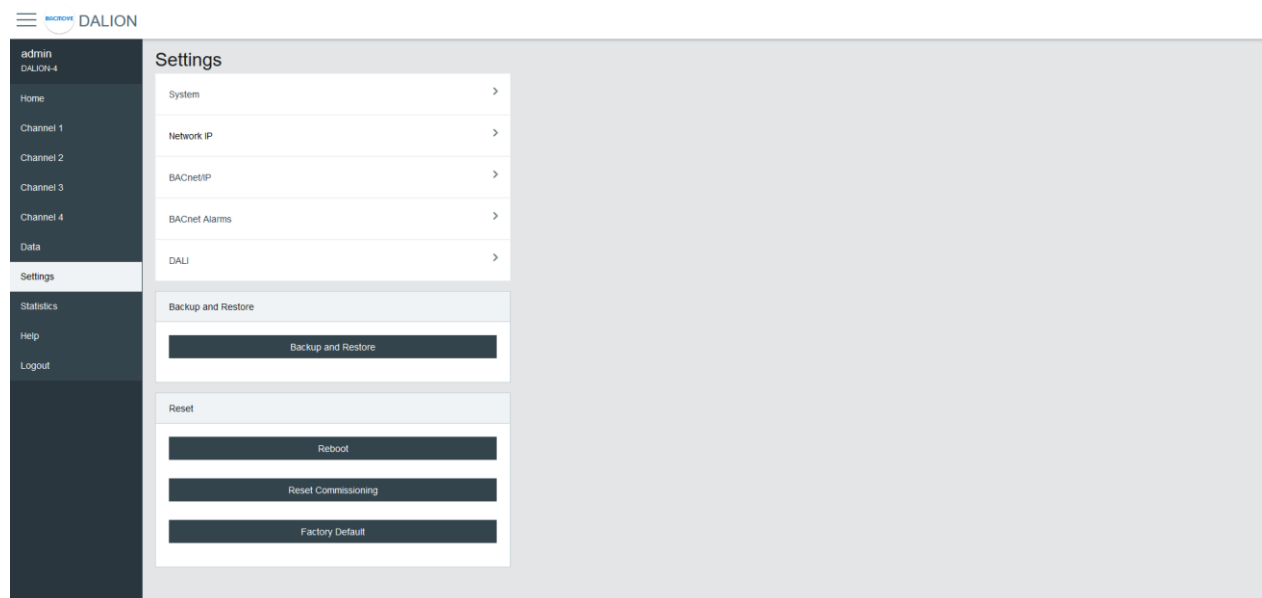

4.4.1 System

The system settings allow changing the username and password.

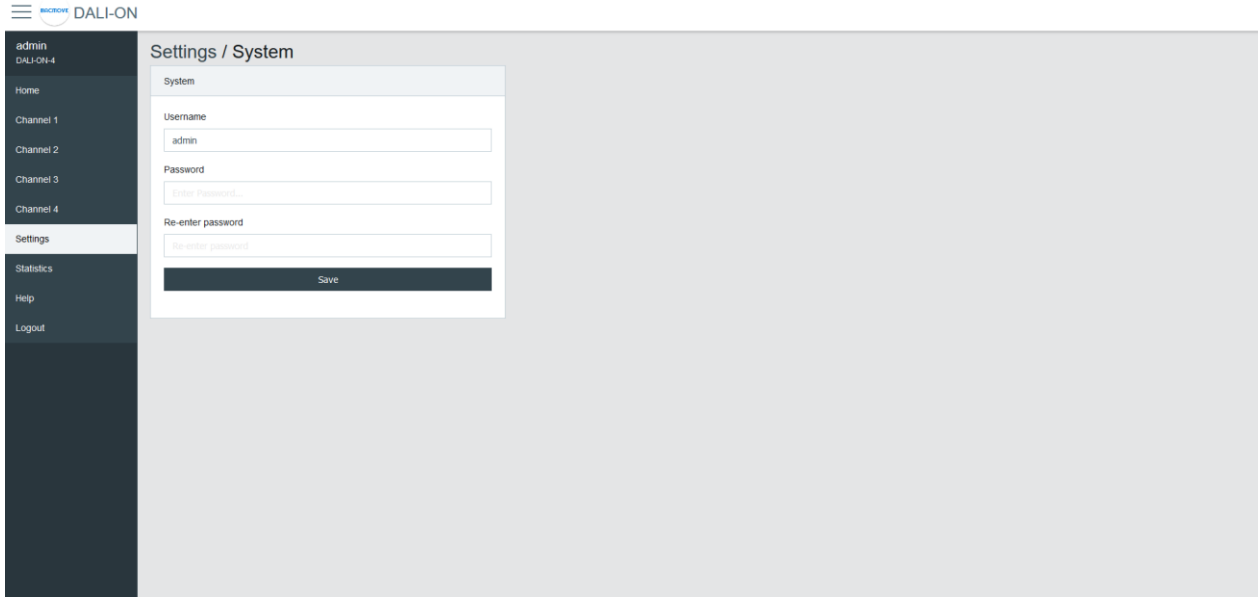

4.4.2 Date Time

Configuration of the system date and time.

4.4.2.1 Time Source

Manual uses the configured date and time. **BACnet** allows setting the date and time with the BACnet TimeSynchronization and UTCTimeSynchronization services.

4.4.2.2 Local Date

The date to configure in 2024-MM-DD format. Where 2024 is the year, MM is the month, and DD is the day. MM and DD must be preceded by a 0 if they are less than 10.

4.4.2.3 Local Time

The time to configure in HH:MM:SS format. Where HH is hours, MM is minutes, and SS is seconds. They must be preceded by a 0 if they are less than 10.

4.4.2.4 Standard Time Zone Offset

The UTC time offset, for the period of the year when the Daylight Saving Time is not active. The format is [+|-]HH:MM. Where [+|-] indicates the sign of the offset, HH the hours and MM the minutes.

Example

For Eastern Time Zone (EST).

-05:00

4.4.2.5 DST Time Zone Offset

The UTC time offset, for the period of the year when the Daylight Saving Time is active. The format is [+|-]HH:MM. Where [+|-] indicates the sign of the offset, HH the hours and MM the minutes.

Example

For Eastern Daylight Time (EDT).

-04:00

4.4.2.6 DST Start - Week

The week of the month when the Daylight Saving Time period starts.

Example

For Eastern Daylight Time (EDT).

2nd

4.4.2.7 DST Start - Day of Week

The day of the week when the Daylight Saving Time period starts.

Example

For Eastern Daylight Time (EDT).

Sunday

4.4.2.8 DST Start - Month

The month when the Daylight Saving Time period starts.

Example

For Eastern Daylight Time (EDT).

March

4.4.2.9 DST End - Week

The week of the month when the Daylight Saving Time period ends.

Example

For Eastern Daylight Time (EDT).

1st

4.4.2.10 DST End - Day of Week

The day of the week when the Daylight Saving Time period ends.

Example

For Eastern Daylight Time (EDT).

Sunday

4.4.2.11 DST End - Month

The month when the Daylight Saving Time period ends.

Example

For Eastern Daylight Time (EDT).

November

4.4.2.12 Hardware UTC Date Time

The currently configured UTC date and time.

4.4.3 Location

Configuration of the local latitude and longitude. The latitude and longitude are used for the calculation of the time of sunrise and sunset for the astronomical time clock schedules.

4.4.3.1 Latitude

The local latitude coordinate that specifies the position of the system in the north or south direction on the surface of the earth. It is measured as an angle, ranging from -90 degrees at the South Pole to 90 degrees at the North Pole, with zero degrees at the Equator.

4.4.3.2 Longitude

The local longitude coordinate specifies the position of the system in the east or west direction on the surface of the Earth. It is measured as an angle, ranging from minus 180 degrees at the westernmost point to 180 degrees at the easternmost point, with zero degrees at the Prime Meridian.

4.4.3.3 Sunrise and Sunset of the Year

The table lists all the calculated sunrise and sunset times for the current year, based on the configured latitude and longitude. The first row displays the times for the current day.

4.4.4 Network IP

Configuration of the IP interface.

By default, the controller uses the IP address **192.168.0.210**. To access the controller:

- Configure the computer on the same subnetwork.
- Open the DALION web interface with a web browser.

Name	Unit	Limit	Default	Description
IP Source	Choice	Static, DHCP	Static	Choice of the IP address source
IP Address	IPv4 Address		192.168.0.210	Static IP address
Netmask	IPv4 Address		255.255.255.0	IP network netmask
Gateway	IPv4 Address		192.168.0.1	IP address of the default gateway
Link Speed / Duplex	Choice	Auto, 100F (100 Mbps Full Duplex), 100H (100 Mbps Half Duplex), 10F (10 Mbps Full Duplex), 10H (10 Mbps Half Duplex)	Auto	Ethernet link speed
DNS Server 1	IPv4 Address		192.168.0.2	IP address of the first DNS server
DNS Server 2	IPv4 Address		192.168.0.3	IP address of the second DNS server
Hostname	String	32 characters	DALION	Network hostname

4.4.5 BACnet/IP

Configuration of the BACnet/IP network interface.

admin
DALI-ON-4

Home

Channel 1

Channel 2

Channel 3

Channel 4

Settings

Statistics

Help

Logout

Settings / BACnet/IP

BACnet/IP

Device Instance: 222638

Name: DALI-ON

Description: DALI-ON

Location: Enter Location...

APDU Timeout: 3000

APDU Retries: 3

UDP Port: 47808

Network Mode: Device

BBMD IP: 0.0.0.0

BBMD Port: 47808

BBMD Registration Delay: 1800

Save

Name	Unit	Limit	Default	Description
Device Instance	Number	0-4194302	222638	BACnet device object instance number
Device Name	String	32 characters	DALION	BACnet device object name
Device Description	String	32 characters	DALION	BACnet device object description
Device Location	String	32 characters		BACnet device object location
APDU Timeout	Number	0-65535	3000	BACnet APDU timeout
APDU Retry Count	Number	0-65535	3	BACnet APDU Retry Count
UDP Port	Number	0-65535	47808	BACnet/IP UDP Port
Network Mode	Choice	Device / Foreign Device	Device	Enable or disable foreign device mode
BBMD IP	IPv4 Address			IP address of the BBMD server
BBMD Port	Number	0-65535	47808	Port of the BBMD server
BBMD Registration Delay	Seconds	0-65535	300	BBMD Registration Delay
Unsubscribed COV Notification - Binary Input	Choice	Enabled / Disabled	Disabled	Enable or disable the sending of unsubscribed COV Notification for the Binary Input objects
Unsubscribed COV Notification - Analog Input	Choice	Enabled / Disabled	Disabled	Enable or disable the sending of unsubscribed COV Notification for the Analog Input objects
Unsubscribed COV Notification - Multi-state Input	Choice	Enabled / Disabled	Disabled	Enable or disable the sending of unsubscribed COV Notification for the Multi-state Input objects
Binary Input - Buttons	Choice	Only Commissioned / All / None	Only Commissioned	Only Commissioned: Only the commissioned input device objects are visible, All: All possible input device objects are visible, None: None of the input device objects are visible.

4.4.6 DALI

Configuration of the DALI channels.

4.4.6.1 Mode

- **Normal:** The controller is operating normally.
- **Disable:** The controller is not authorized to communicate on the DALI channel. When the mode is **Disable**, gray bands appear in the background of the associated DALI channel pages.

4.4.6.2 Lamp Command Repeat Count

The commands that affect the light intensity of the lamps can be repeated.

4.4.6.3 Assign Match Short Address with Index

If enabled when assigning a lamp or input, its short address will automatically be modified to match the assignment index number.

4.4.7 BAS Communication Timeout

In the event of loss of communication between the DALION and another BACnet device such as a BAS (Building Automation System), the DALI channels and groups can reach a specified light brightness. The commands executed when the timeout is reached are configured through the pages of each group and channels.

The screenshot displays the DALION web interface. On the left is a dark sidebar menu with the following items: 'admin DALION-4', 'Home', 'Channel 1', 'Channel 2', 'Channel 3', 'Channel 4', 'Data', 'Settings' (highlighted), 'Statistics', 'Help', and 'Logout'. The main content area is titled 'Settings / BAS Communication Timeout'. It features a form for configuring the 'BAS (Building Automation System) Communication Timeout'. The form includes the following fields and controls:

- Enable:** A dropdown menu currently set to 'Enable'.
- BACnet Device Id:** A text input field containing '10100'.
- Initial Delay (seconds):** A text input field containing '60'.
- Delay (seconds):** A text input field containing '900'.
- Timeout Level (DALI Level 0-255):** A text input field containing '100'.
- Save:** A dark button at the bottom of the form.

Name	Unit	Limit	Default	Description
Enable	Choice	Enable / Disable	Disable	Enable or disable the communication timeout
BACnet Device Id	Number	0-4194302	0	BACnet device id of the other device (BAS)
Initial Delay	Number	0-4194302	0	Initial Delay in seconds. Used to let time to the other device (BAS) to boot-up
Delay	Number	0-65535	0	Delay in seconds before the communication timeout
Timeout Level	Number	0-255	0	Default light intensity level

4.4.8 Backup / Restore

This page allows to backup and restore the configuration and the commissioning data.

The “**Backup**” section allows downloading configuration files from the controller. The “**Restore**” section allows going back to a previous configuration, with a configuration file downloaded to the controller. The Tool software must be used to perform the restore.

4.4.9 Reboot

This page allows the system to restart. Some configurations, such as network settings, require a system reboot.

4.4.10 Reset Commissioning

This page removes the commissioning data by deleting all lamps, groups, and scenes from the configuration. The commissioning data can be reset for each channel individually.

4.4.11 Factory Default

This page allows resetting all settings and commissioning data to their factory default values.

4.5 DALI Commissioning

4.5.1 Lamps

This page displays the list of commissioned lamps. The list provides a descriptive **Name** of each lamp as well as other information like **Actual Level**, **Type** and short address **S.A.**.

<input type="checkbox"/>	Name	Type	Status	S.A.	Action
<input type="checkbox"/>	Lamp 1-00	LED	100%	0	On Off More ▾
<input type="checkbox"/>	Lamp 1-01	Colour	100% #2092ef	1	On Off More ▾
<input type="checkbox"/>	Lamp 1-02	Colour	100% 5988K	2	On Off More ▾
<input type="checkbox"/>	Lamp 1-03	LED	100%	3	On Off More ▾
<input type="checkbox"/>	Lamp 1-04	Colour	100% 2702K	4	On Off More ▾
<input type="checkbox"/>	Lamp 1-05	LED	100%	5	On Off More ▾

Lamps can be turned **On**, **Off** or we can **Set Level** in a percentage of its light intensity. **Notify** helps to identify a lamp by dimming it in a loop between its minimum and maximum light intensity. **Unassign** removes the lamp from the list of lamps while **Delete** also removes the lamp from the list, but also resets its DALI parameters to the default values.

For the lamps with colour control, available with DALI Type 8 (DT8) lamps, the current colour can be modified with **Set Colour**.

By clicking on a lamp row, the Lamp Parameters page opens.

4.5.2 Lamp Parameters

This page allows the configuration of lamp parameters.

admin
DALI-ON-4

Home

Channel 1

Channel 2

Channel 3

Channel 4

Settings

Statistics

Help

Logout

Channel 1 / Lamp 1-01 / Main Office

Parameters

Actual Level %	<input type="text" value="100"/>	SET
Name	<input type="text" value="Lamp 1-01 / Main Office"/>	SET
Power On Level %	<input type="text" value="100"/>	SET
System Failure Level %	<input type="text" value="100"/>	SET
Minimum Level %	<input type="text" value="0.1"/>	SET
Maximum Level %	<input type="text" value="100"/>	SET
Fade Rate steps/s	<input type="text" value="44.7"/>	SET
Fade Time seconds	<input type="text" value="4.0"/>	SET
Short Address	<input type="text" value="11"/>	SET
Run Hours (seconds)	<input type="text" value="870"/>	SET
Burn-In (seconds)	<input type="text" value="0"/>	SET

BACnet Object: Analog Output/Input 0

Reliability: 0 (no-fault-detected)

Name	Unit	Minimum	Maximum	Default	Description
Actual Level	Percent	0%	100%		Actual light intensity
Name	String		32 characters		Name of the lamp
Power On Level	Percent	0%	100%	100%	Level of intensity after a power on
System Failure Level	Percent	0%	100%	100%	Level of intensity when system failure
Minimum Level	Percent	0.1%	100%	100%	Minimum level of intensity
Maximum level	Percent	0.1%	100%	100%	Maximum level of intensity
Fade Rate	Choice	2.8	358	44.7	Fade rate in steps per second
Fade Time	Choice	No Fade	90.5	No Fade	Fade time in seconds
Short Address	Number	0	63		The short address
Run Hours	Number	0	65535	0	Number of seconds where the lamp was on
Nominal Power	Number	0	4294967	0	Nominal power
Burn-In	Number	0	65535	0	Number of seconds remaining to the burn-in
Dimming Curve	Choice	Logarithmic	Linear	Logarithmic	Dimming curve
Energy Usage Accumulated	Number	0	42949672	0	Energy usage accumulated
BACnet Object					The BACnet object associated with the lamp
Reliability					Reliability of the lamp

4.5.3 Emergency Parameters

For the lamps of the type “Self-contained emergency lighting (device type 1)”, other parameters are available. When emergency parameters are available, a tab **Emergency** is added.

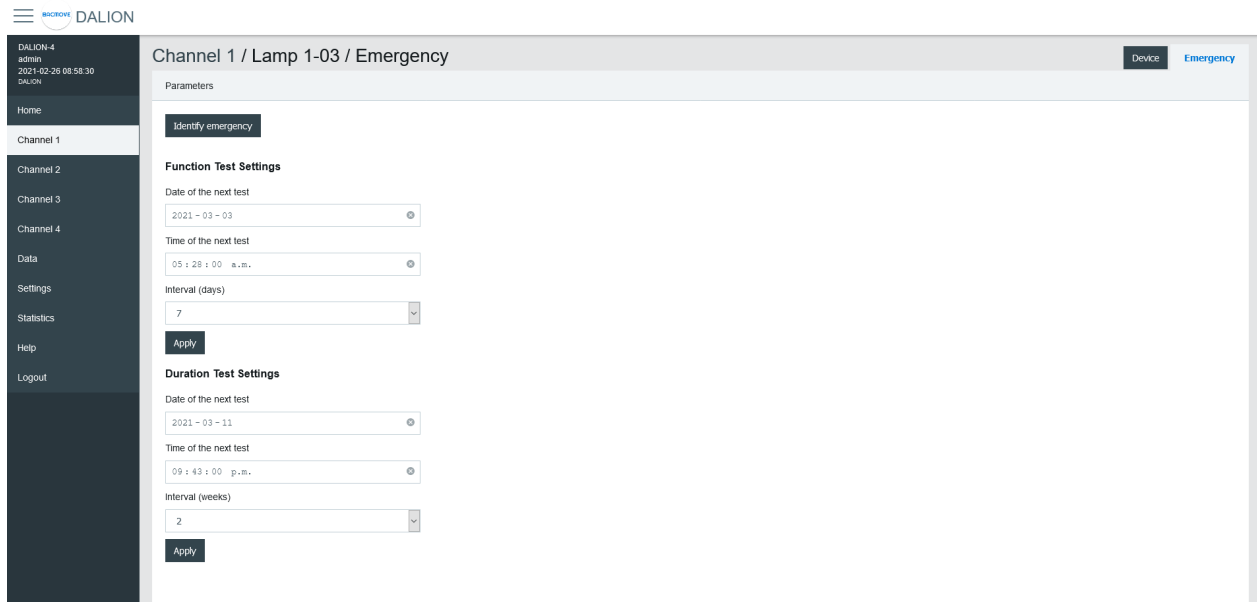

4.5.3.1 Identify emergency

Allows for the identification of the emergency lamp.

4.5.3.2 Function Test Settings

Allows the configuration of the interval for the function test.

4.5.3.3 Duration Test Settings

Allows the configuration of the interval for the duration test.

4.5.3.4 Prolong

Allows for the configuration of the prolong time.

4.5.3.5 Features

Show the features bits values.

4.5.3.6 Emergency Mode

Show the emergency mode bits value.

4.5.3.7 Emergency Status

Show the emergency status bits value.

4.5.3.8 Failure Status

Show the failure status bits value.

4.5.3.9 Timings

Show to values of the timings.

4.5.3.10 Other modes

Allows modifying the inhibit and rest modes.

4.5.4 Colour Parameters

For the lamps with colour control, available with DALI Type 8 (DT8) lamps, other parameters are available. When colour parameters are available, a tab **Colour** is added.

Name	Description
Actual Colour	Actual colour
Power On Colour	Colour after a power on
System Failure Colour	Colour when system failure
Gear Features/Status	DALI features of the lamp
Colour Type Features	DALI colour features of the lamp
Scenes 1-16	Colour for the scenes 1 to 16
Tc Warmest Kelvin (1)	Warmest colour temperature in Kelvin
Tc Coolest Kelvin (1)	Coolest colour temperature in Kelvin
Tc Physical Warmest (1)	Physical warmest colour temperature in Kelvin
Tc Physical Coolest (1)	Physical coolest colour temperature in Kelvin
RGBWAF Control (2)	RGBWAF Control
RGBWAF Assigned Colour (2)	RGBWAF Assigned Colour

(1) Only available for lamps with the colour type; colour temperature Tc.

(2) Only available for lamps with the colour type; RGBWAF.

4.5.5 Colour Picker

When using **Set Colour** menu or the **Pick Colour** button a window appear to allow choosing the desired colour.

The window allows defining the colour according to the types of colours available for the selected lamp.

When a value is **MASK**, this value is not modified.

For example, it is possible to set only the green colour, without affecting the red and blue colour.

4.5.5.1 *xy-Coordinate*

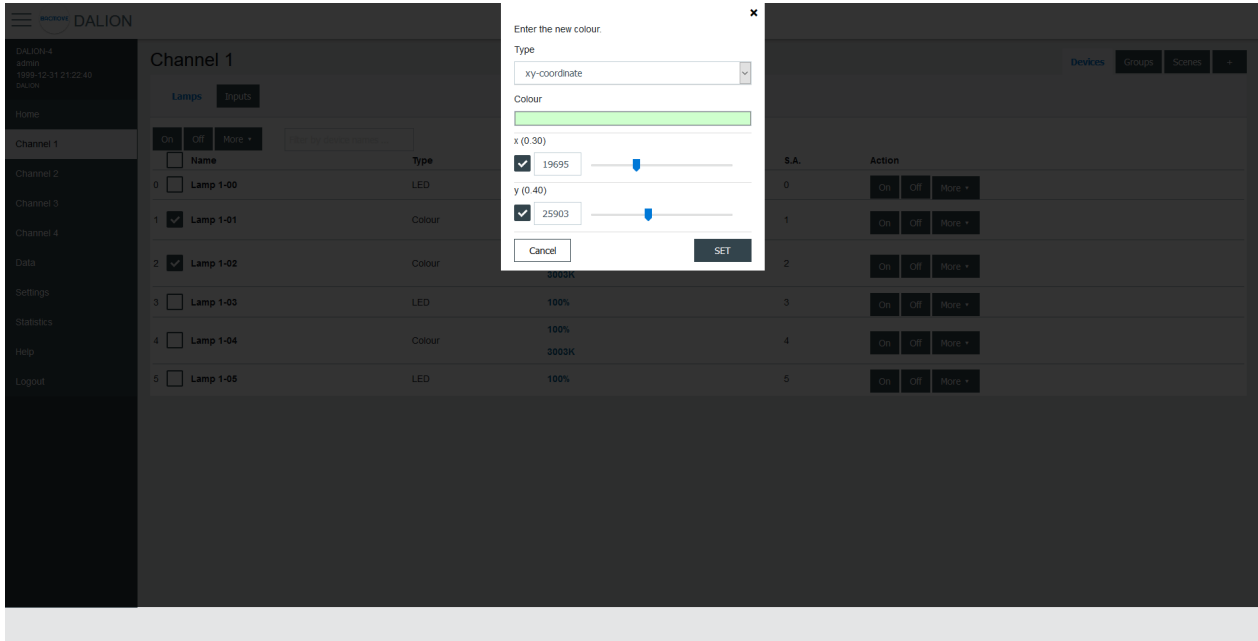

Name	Unit	Minimum	Maximum	Default	Description
Colour Preview (1)	RGB				Clicking on the colour will open the browser colour picker.
x	1 / 65536	0	65534		
y	1 / 65536	0	65534		

(1) Colour is for demonstration purposes only, the resulting lamp colour may be different.

4.5.5.2 colour temperature Tc

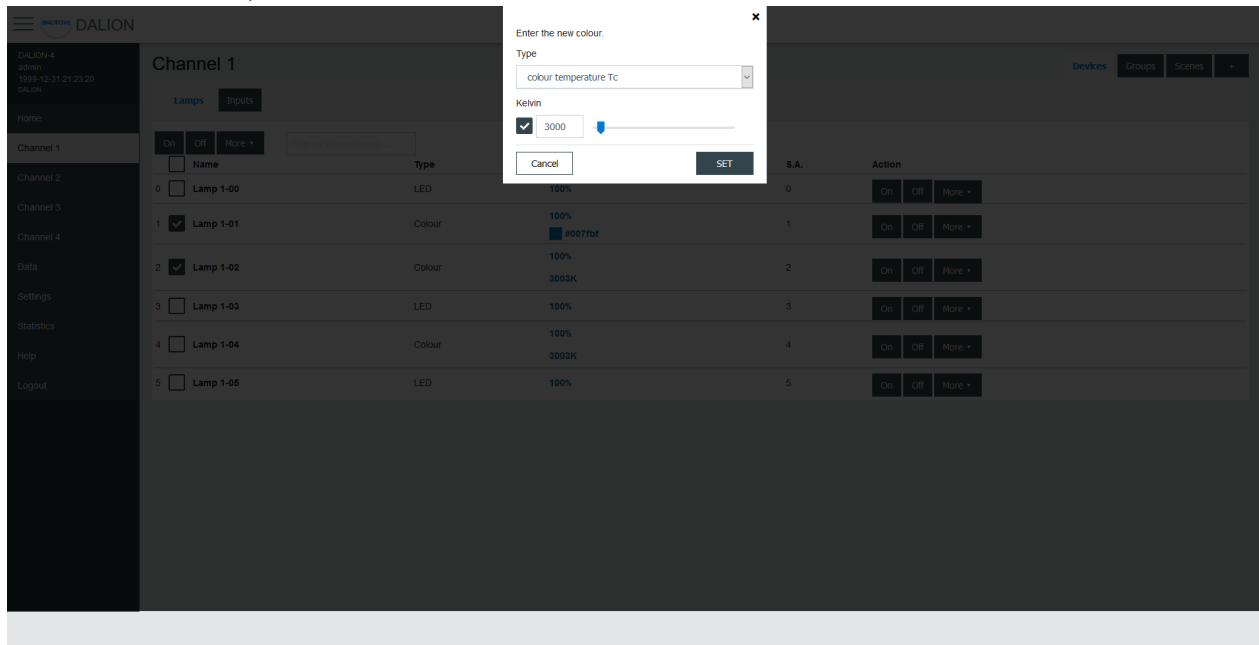

Name	Unit	Minimum	Maximum	Default	Description
Kelvin	Kelvin	16 (1)	1 000 000 (1)		Colour temperature in Kelvin

(1) The minimum and maximum Kelvin are also limited by the warmest and coolest parameters.

4.5.5.3 primary N

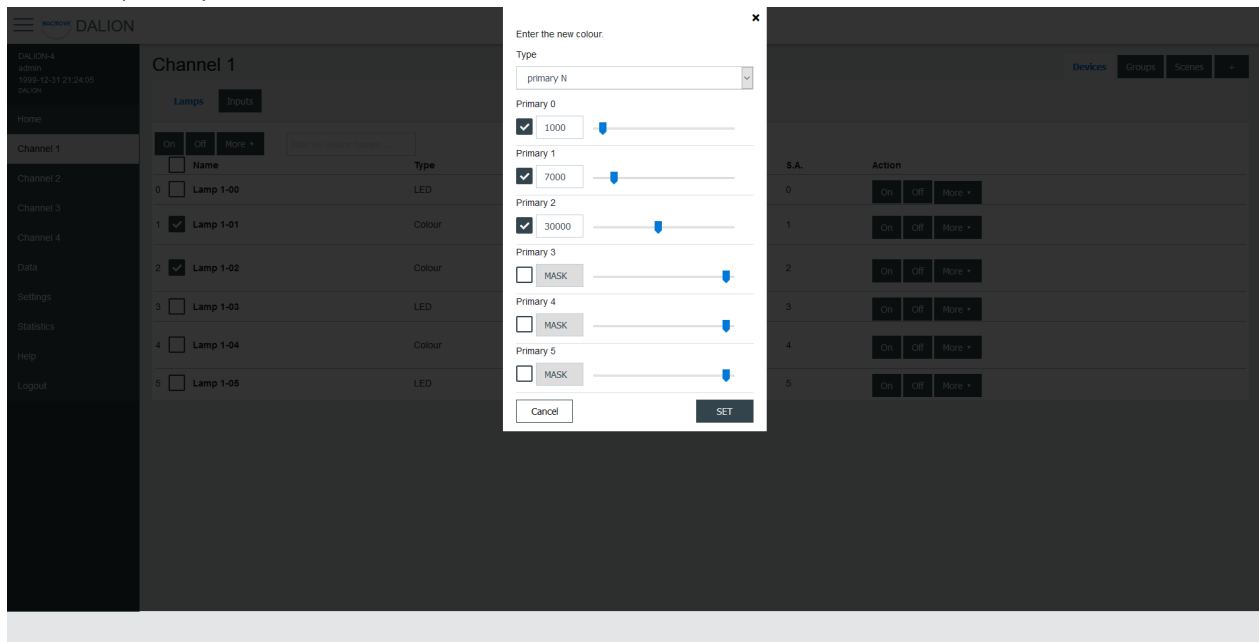

Name	Unit	Minimum	Maximum	Default	Description
Primary 0-5		0	65534		Primay value

4.5.5.4 RGBWAF

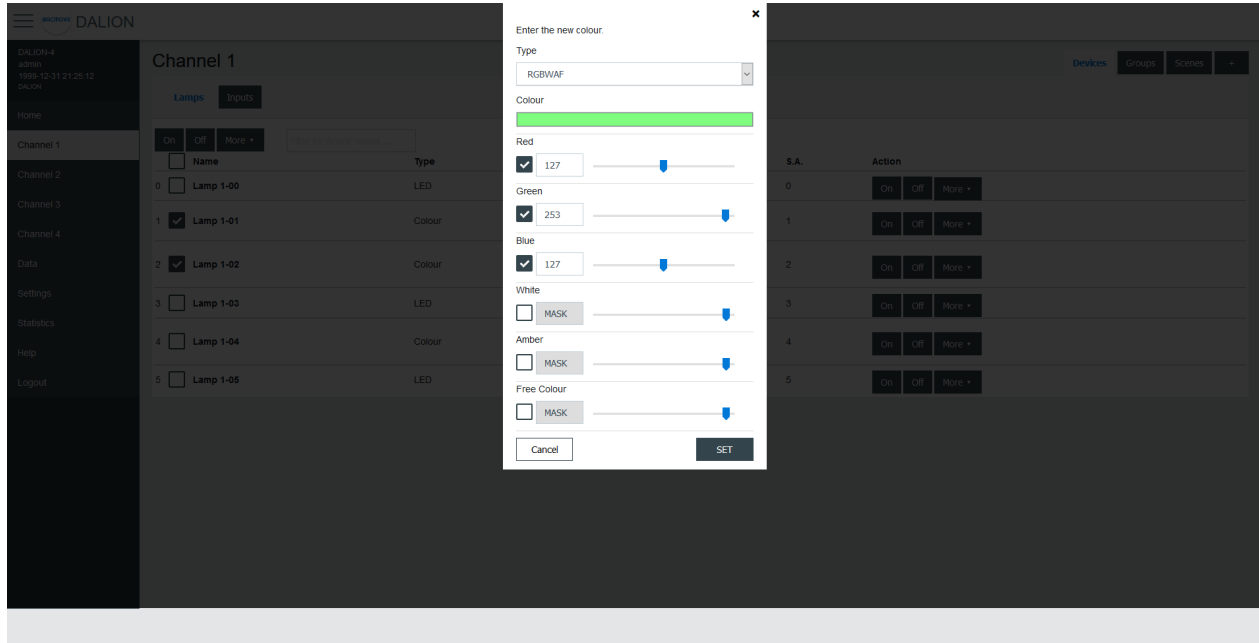

Name	Unit	Minimum	Maximum	Default	Description
Colour Preview (1)	RGB				Clicking on the colour will open the browser colour picker.
Red		0	254		Red colour value
Green		0	254		Green colour value
Blue		0	254		Blue colour value
White		0	254		White colour value
Amber		0	254		Amber colour value
Freecolour		0	254		Freecolour colour value

(1) Colour is for demonstration purposes only, the resulting lamp colour may be different.

4.5.6 Groups

There are 16 groups for the lamps and each lamp can be part of any combination of the 16 groups. This page allows visualization and control of the groups.

The first line is indicated by a * and is the channel. The underlying lines are numbered for the 16 groups.

It is possible to:

- turn **On** or **Off** the group

- **Set Level** of the group intensity
 - **Recall, Store** and **Delete** the group scenes
- By clicking on a group row, the Group Parameters page opens.

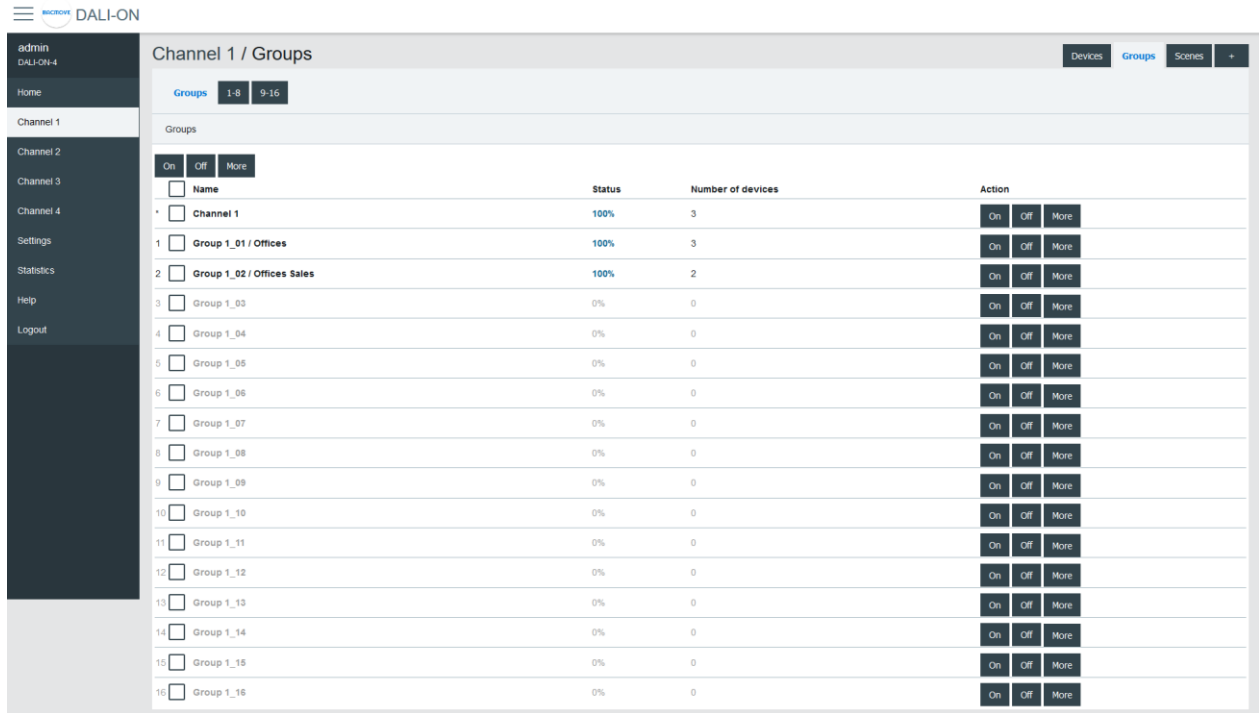

4.5.7 Group Parameters

This page allows the configuration of group parameters.

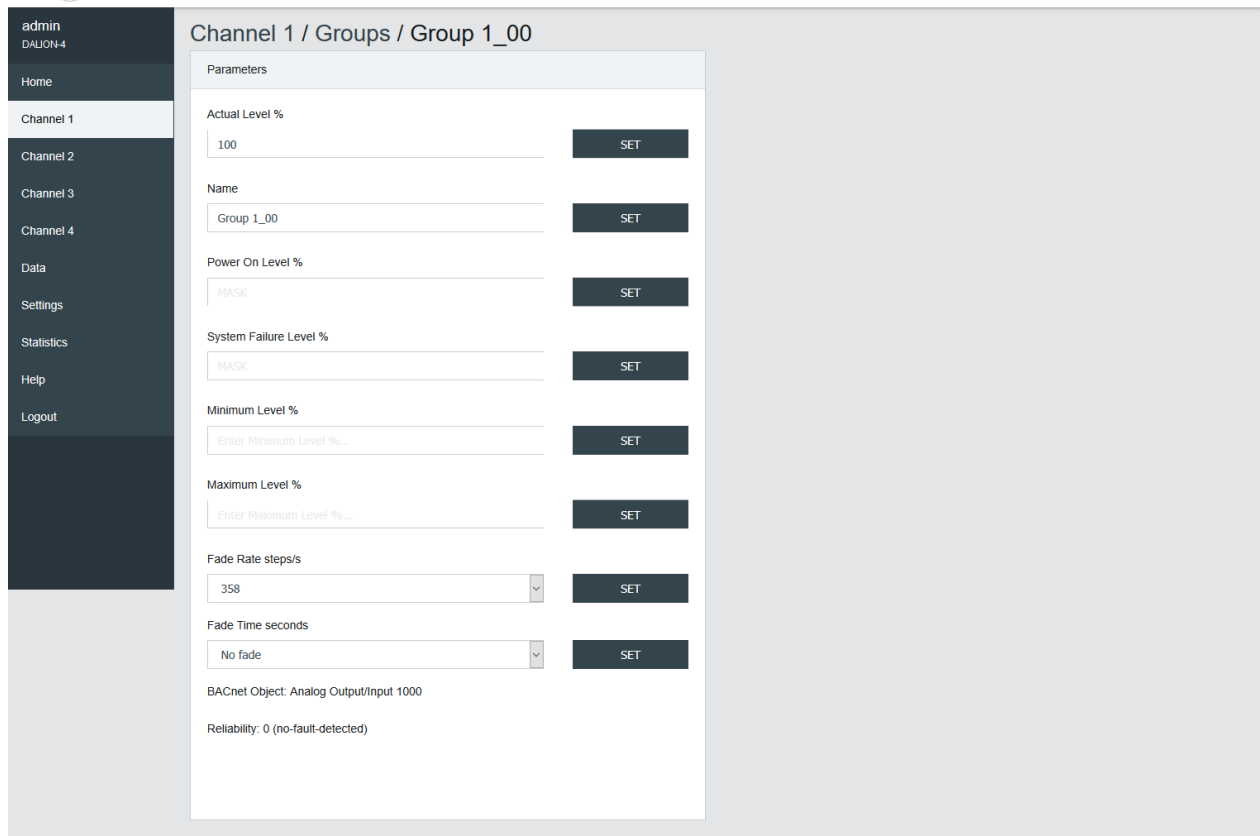

Name	Unit	Minimum	Maximum	Default	Description
Actual Level	Percent	0%	100%		Actual group intensity
Name	String		32 characters		Name of the group
BACnet Object	String				BACnet object identifier of the group
Reliability	String				BACnet reliability of the group object
BAS Timeout Command	Choice			No Command	The command executed when communication is lost with another BACnet device (BAS). No Command, Off, On or Timeout Level.

Group names provide textual identification for each group. The intensity level of the groups can be changed. Once it is modified, all lamps in the group must reach the same brightness level.

Certain parameters of the DALI lamps can be sent to all the lamps which are part of the group.

Name	Unit	Minimum	Maximum	Default	Description
Power On Level	Percent	0%	100%	100%	Level of intensity after a power on
System Failure Level	Percent	0%	100%	100%	Level of intensity when system failure
Minimum Level	Percent	0.1%	100%	100%	Minimum level of intensity
Maximum level	Percent	0.1%	100%	100%	Maximum level of intensity
Fade Rate	Choice	2.8	358	44.7	Fade rate in steps per second
Fade Time	Choice	No Fade	90.5	No Fade	Fade time in seconds
Dimming Curve	Choice	Logarithmic	Linear	Logarithmic	Dimming curve

4.5.8 Groups 0-7 / 8-15

For easy visualization and assignment of the 16 groups, they are separated in views of eight groups (i.e., Groups 0-7 and Groups 8-15).

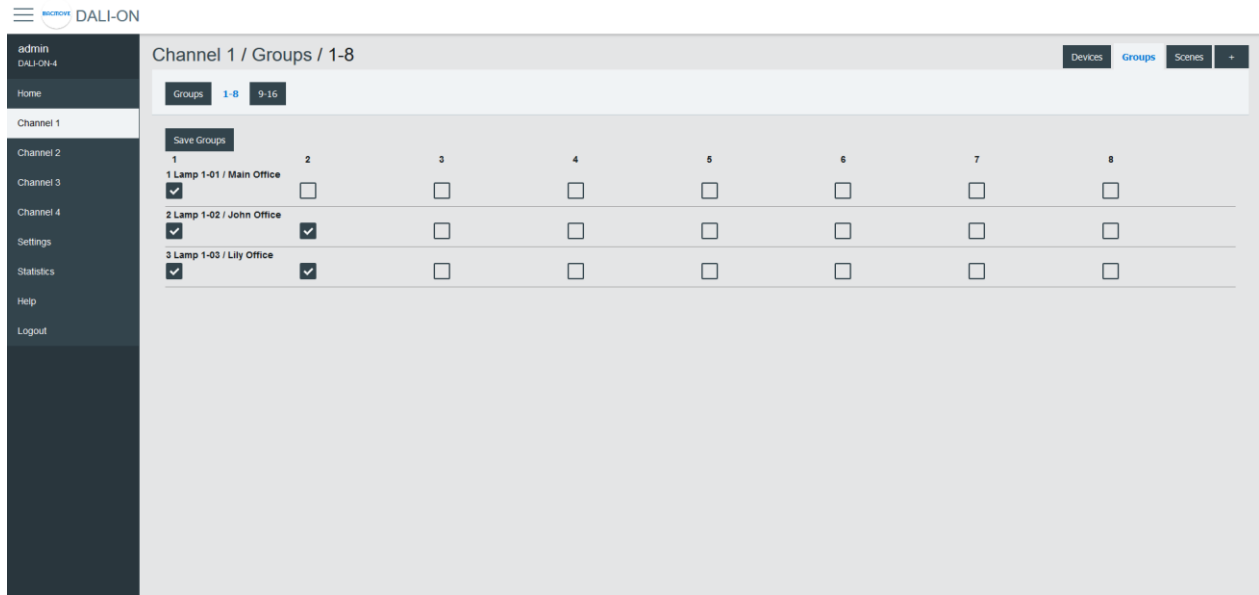

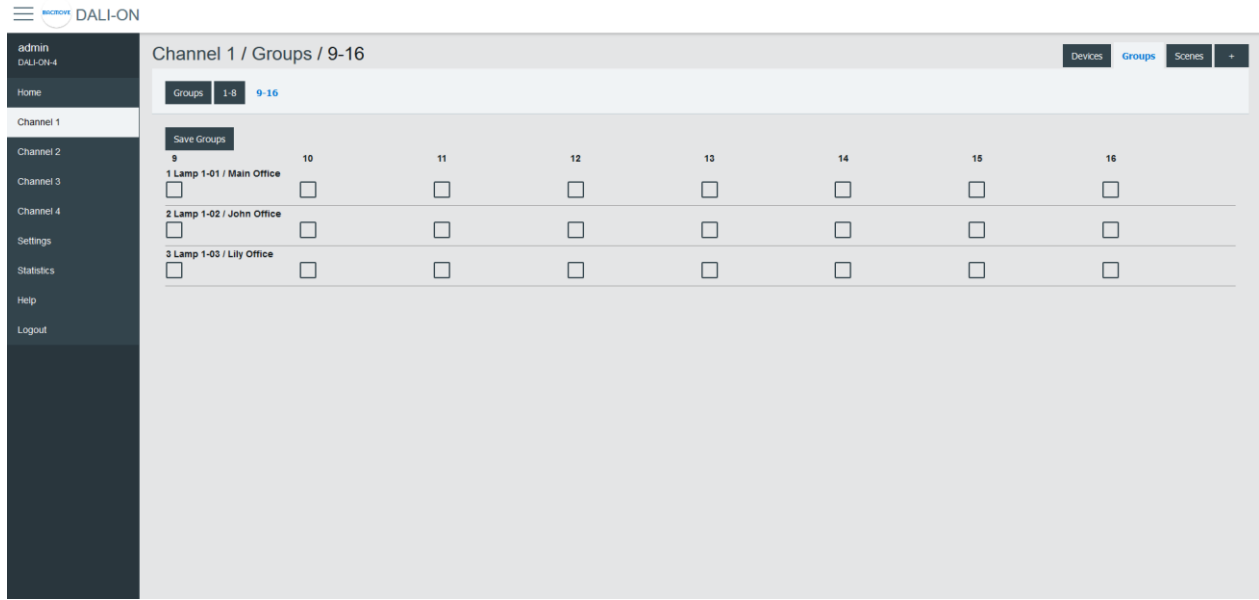

4.5.9 Scenes

Each lamp has 16 scenes. A scene is a level of light intensity in percentages. The value of a scene can also be left empty. Scenes control can be sent to a single lamp, a group of lamps, or the entire DALI channel. When a scene is recalled, all the addressed lamps are invited to dim their brightness at the same brightness level.

For lamps with colour control (i.e., DT8), the 16 scenes can also recall the colour levels. The configuration of the scene colour levels should be performed in the Colour page of each lamp.

4.5.10 Scenes Control

Scenes can be recalled, stored or deleted. Once the desired group or broadcast destination is selected and the **Recall**, **Store** or **Delete** action is also selected, one of the 16 scenes can be performed.

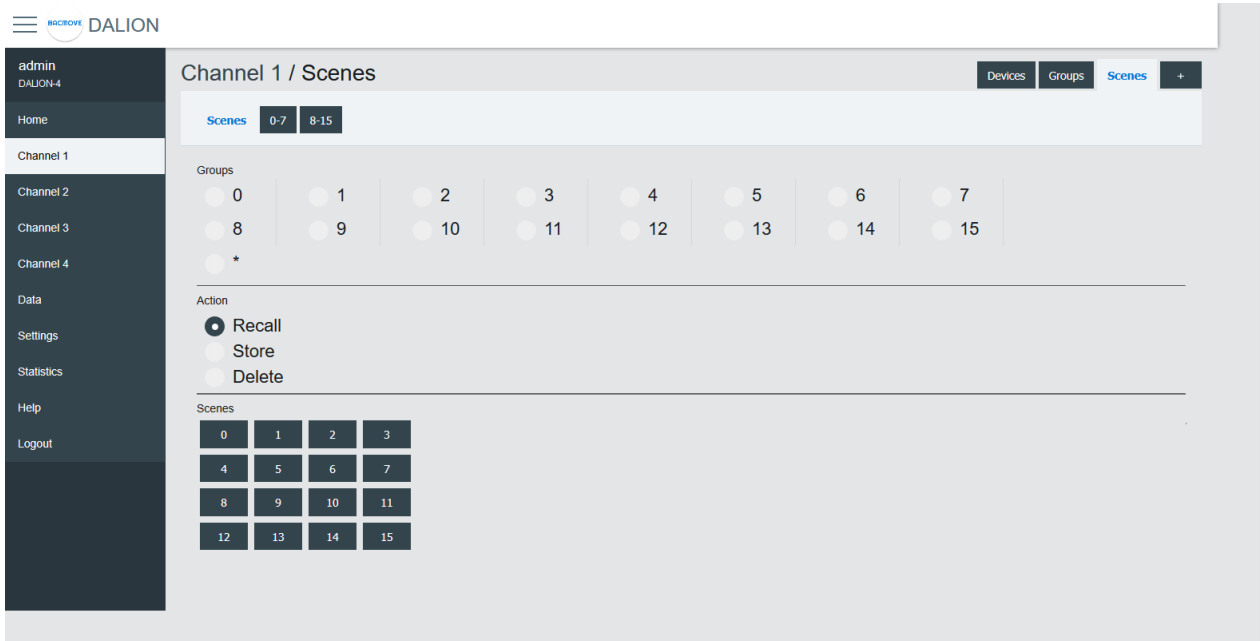

4.5.11 Scenes 0-7 / 8-15

For easy visualization and configuration of the 16 scenes, they are separated in views of eight scenes (i.e., Scenes 0-7 and Scenes 8-15).

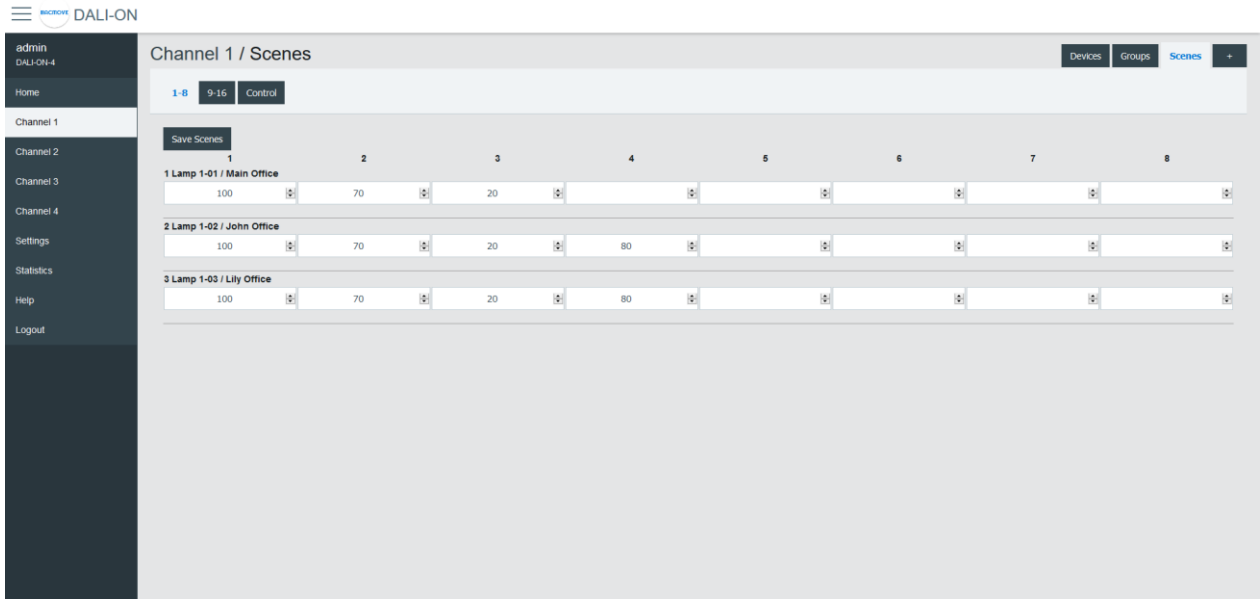

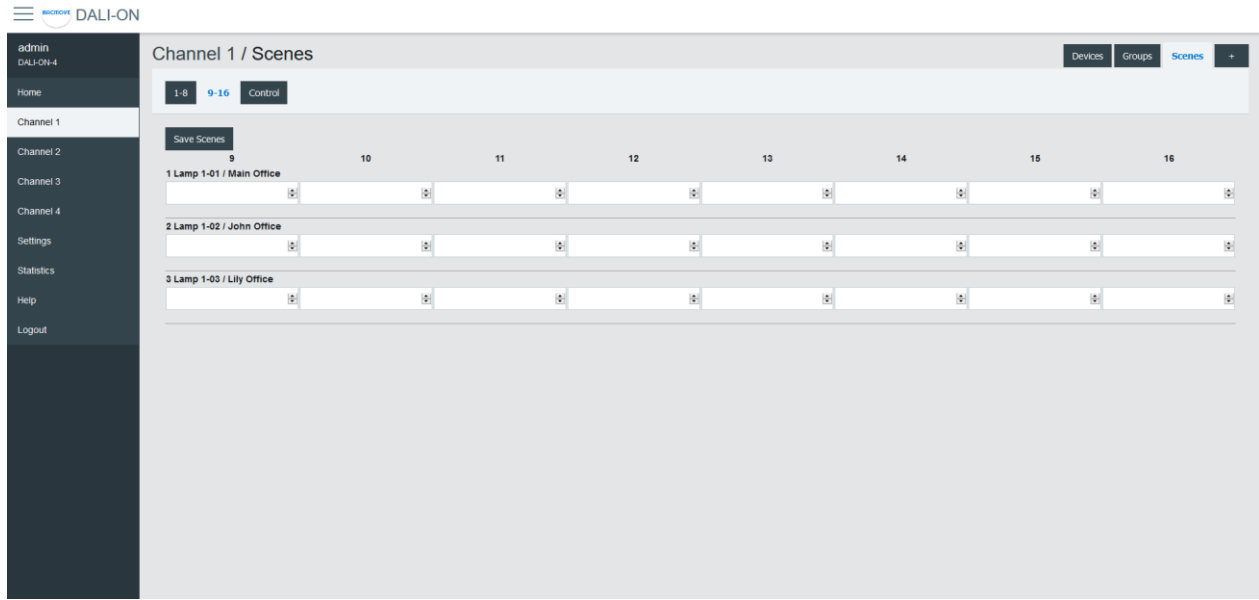

4.5.12 Memory Bank

This page allows read, editing and writing DALI memory banks of lamps and DALI-2 input devices.

4.5.13 Inputs

This page displays the list of commissioned DALI light sensors, occupancy sensors and buttons. The list provides a descriptive **Name** of each input device as well as other information like occupancy state, light value, types and short address.

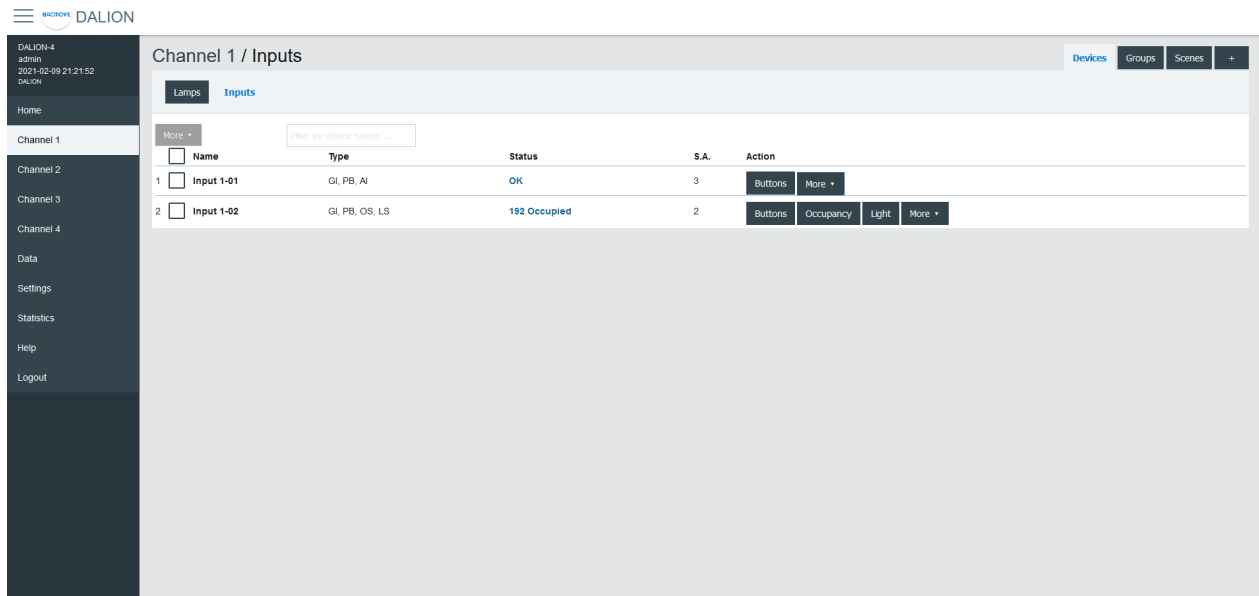

Inputs devices can identify themselves with the **Identify** button.

The  icon indicates that Buttons or Occupancy commands are prohibited. See the network properties Allowed_Command or Buttons_Allowed_Command for more information.

By clicking on an input row, the Input Parameters page opens.

4.5.13.1 Input Parameters

This page allows the configuration of input parameters.

4.5.13.1.1 Parameters

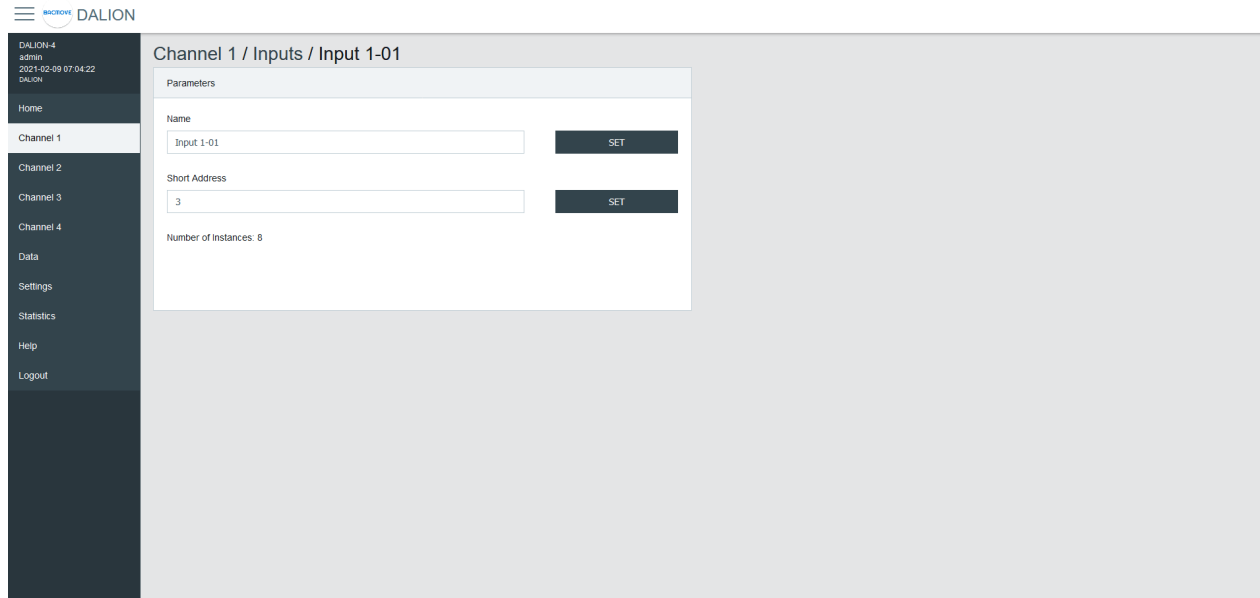

Name	Unit	Minimum	Maximum	Default	Description
Name	String		32 characters		Name of the device
Short Address	Number	0	63		The short address
Number of instances	Number	1	32		Displays the number of instances

4.5.13.1.2 Instances Value

Display of the values of the input instances.

Instances Value			
Instance	Type	Value	Configuration
0	Push-Button	Toggle 0	Buttons
1	Push-Button	Toggle 0	Buttons
2	Push-Button	Toggle 0	Buttons
3	Push-Button	Toggle 0	Buttons

4.5.13.1.3 Command Allowed

Display and modification of the allowed commands for the occupation and button inputs.

Command Allowed			
Type	Command Allowed		
Occupancy	Off, On	Disable Off	Disable On
Button	Off, On	Disable Off	Disable On

4.5.13.2 Buttons

Each input device support up to 32 button instances. The command and destination for each instance are configurable by clicking on an instance row.

DALION-4
admin
2021-02-09 21:25:19
DALION

- Home
- Channel 1
- Channel 2
- Channel 3
- Channel 4
- Data
- Settings
- Statistics
- Help
- Logout

Channel 1 / Inputs / Input 1-01 / Buttons

Button Instances						
Instance	Function	Press Time (ms)	Command	Value 1	Value 2	Destination
0	Push-button	500	Max Level / Up	0	0	Group 1-00 (Channel 1 / Group 00)
3	Push-button	500	Off / Down	0	0	Group 1-00 (Channel 1 / Group 00)
6	Push-button	500	Recall Scene	1	0	Group 1-00 (Channel 1 / Group 00)
7	Push-button	500	Recall Scene	2	0	Group 1-00 (Channel 1 / Group 00)

4.5.13.3 Button Parameters

DALION-4
admin
2021-02-09 06:20:22
DALION

- Home
- Channel 1
- Channel 2
- Channel 3
- Channel 4
- Data
- Settings
- Statistics
- Help
- Logout

Channel 1 / Inputs / Input 1-01 / Buttons / 0

Button Parameters

Instance Values

Function:

Press Time (ms):

Destination:

Command:

Value 1:

Value 2:

All Instances Values

Repeat Time (ms):

Name	Description
Function	Push-button or Switch
Press Time	Press time in milliseconds
Destination	Destination of the command
Command	Choice of the button command
Value 1	First value of the command
Value 2	Second value of the command

4.5.13.3.1 Function

Name	Description
Push-button	Actuated when the button is temporarily pressed
Switch	Actuated when the button position is toggled

4.5.13.3.2 Press Time

The time in milliseconds before registering a button press.

4.5.13.3.3 Repeat Time (ms)

The time in milliseconds between repeated commands. This parameter is the same for all instances of the same device.

4.5.13.3.4 Destination

The destination of the command can be a DALI group or a DALI channel.

4.5.13.3.5 Command

4.5.13.3.5.1 Push-button

Name	Short Press	Long Press	Long Press Repeat
Disabled			
Direct Value	Direct Value Value 1 %		
Max Level	Recall Max Level		
Max Level / Up	Recall Max Level	On and Step Up	Up
Off	Off		
Off / Down	Off	Step Down and Off	Down
Min Level	Min Level		
Min Level / Down	Min Level	Step Down and Off	Down
Recall Scene	Recall Scene Value 1 0-15		
Recall Scene / Up	Recall Scene Value 1 0-15	On and Step Up	Up
Recall Scene / Down	Recall Scene Value 1 0-15	Step Down and Off	Down
On / Off	Toggle between Recall Max Level and Off		
Last Level	Recall Last Level		
Last Level / Up	Recall Last Level	On and Step Up	Up
Last Level / Off	Toggle between Last Level and Off		
RLC: Occupancy - Unoccupied	Toggle occupancy state, 1 is unoccupied.		
RLC: Occupancy - Occupied	Toggle occupancy state, 1 is occupied		
RLC: Daylight Harvesting - Stop	Stop daylight harvesting		
RLC: Daylight Harvesting - Start	Start daylight harvesting		
RLC: Demand Response - Stop	Stop demand response		

RLC: Demand Response - Start demand response
Start

4.5.13.3.5.2 Switch

Name	Open switch	Close switch
Disabled		
Direct Value	Direct Value Value 2 %	Direct Value Value 1 %
Max Level		Recall Max Level
Max Level / Up		Recall Max Level
Off		Off
Off / Down		Off
Min Level		Min Level
Min Level / Down	Min Level	Min Level
Recall Scene	Recall Scene Value 1 0-15	Recall Scene Value 2 0-15
Recall Scene / Up	Recall Scene Value 1 0-15	Recall Scene Value 2 0-15
Recall Scene / Down	Recall Scene Value 1 0-15	Recall Scene Value 2 0-15
On / Off	Off	On
Last Level		Recall Last Level
Last Level / Up		Recall Last Level
Last Level / Off	Off	On
RLC: Occupancy - Unoccupied	Occupied	Unoccupied
RLC: Occupancy - Occupied	Unoccupied	Occupied
RLC: Daylight Harvesting - Stop	Start daylight harvesting	Stop daylight harvesting
RLC: Daylight Harvesting - Start	Stop daylight harvesting	Start daylight harvesting
RLC: Demand Response - Stop	Start demand response	Stop demand response
RLC: Demand Response - Start	Stop demand response	Start demand response

4.5.13.3.6 Value 1

First value of the command.

4.5.13.3.7 Value 2

Second value of the command.

4.5.13.4 Occupancy Sensor

Each input device supports up to one occupancy sensor instance.

Channel 1 / Inputs / Input 1-02 / Occupancy

Occupancy Parameters

Hold Time (seconds)

900

Save

Name	Unit	Minimum	Maximum	Default	Description
Hold Time	Seconds				Hold time in seconds

4.5.13.5 Light Sensor

Each input device supports up to one light sensor instance.

Channel 1 / Inputs / Input 1-02 / Light

Light Parameters

Hysteresis (%)

5

Hysteresis Minimum

255

Save

Name	Unit	Minimum	Maximum	Default	Description
Hysteresis					Hysteresis in percentage
Hysteresis Minimum					Hysteresis minimum

To prevent flooding the DALI network with an excessive number of events triggered by minor changes in illuminance levels, a hysteresis band is present in the light sensor.

The hysteresis band is determined as the greater of the following values:

- The Hysteresis in percentage of the sensor internal current illuminance level.
- The Hysteresis Minimum.

4.5.13.5.1 Hysteresis

This is a percentage of the current sensor internal illuminance level.

The valid values are from 0 to 25 percent.

4.5.13.5.2 Hysteresis Minimum

The minimum hysteresis.

The valid values are from 0 to 255.

4.5.13.6 Light Sensor Calibration

Light sensor calibration involves using a lux meter to measure the ambient light intensity. By comparing the value of the sensor with the lux meter reading, you can adjust the sensor to ensure accurate and consistent measurements. This process ensures that the output of the sensor corresponds accurately to the actual light intensity in lux.

Light Sensor Calibration						
Search Light Sensor...						
<input type="checkbox"/>	Channel	Index	Name	Measured	Sensor Value	Set
<input type="checkbox"/>	1	0	Input 1-00 Light	500	519	Calibrate Set
<input type="checkbox"/>	1	1	Input 1-01 Light			Set
<input type="checkbox"/>	1	2	Input 1-02 Light			Set
<input type="checkbox"/>	1	3	Input 1-03 Light			Set
<input type="checkbox"/>	1	4	Input 1-04 Light			Set
<input type="checkbox"/>	1	5	Input 1-05 Light			Set
<input type="checkbox"/>	1	6	Input 1-06 Light			Set
<input type="checkbox"/>	1	7	Input 1-07 Light			Set
<input type="checkbox"/>	1	8	Input 1-08 Light			Set
<input type="checkbox"/>	1	9	Input 1-09 Light			Set
<input type="checkbox"/>	1	10	Input 1-10 Light			Set
<input type="checkbox"/>	1	11	Input 1-11 Light			Set
<input type="checkbox"/>	1	12	Input 1-12 Light			Set
<input type="checkbox"/>	1	13	Input 1-13 Light			Set
<input type="checkbox"/>	1	14	Input 1-14 Light			Set
<input type="checkbox"/>	1	15	Input 1-15 Light			Set
<input type="checkbox"/>	1	16	Input 1-16 Light			Set
<input type="checkbox"/>	1	17	Input 1-17 Light			Set

4.5.13.6.1 Light Sensors List

It list the calibration for each light sensor.

4.5.13.6.1.1 Collumns

4.5.13.6.1.1.1 Checkbox

Allows the manual calibration of the multiple selected light sensors.

4.5.13.6.1.1.2 Channel

The light sensor channel number, 1 to 4.

4.5.13.6.1.1.3 Index

The light sensor index number, 0 to 31.

4.5.13.6.1.1.4 Name

The light sensor name.

4.5.13.6.1.1.5 Measured

The value measured with a lux meter for calibration.

4.5.13.6.1.1.6 Sensor Value

The light sensor reading value used for calibration.

4.5.13.6.1.1.7 Calibrate Button

Opens the light sensor calibration.

Enter the value obtained from the lux meter and press the Calibrate button.

The Reset button clears the calibration, allowing the use of the light sensor value without calibration.

The image shows a dialog box with a black border and a close button (X) in the top right corner. The text inside reads: "Enter the measured lux level for 'Input 1-00 Light'." Below this text is a text input field containing the number "500". To the right of the input field is a dark blue button labeled "Calibrate". Below the input field and "Calibrate" button is another dark blue button labeled "Reset".

4.5.13.6.1.1.8 Set Button

Opens the manual calibration for the light sensor.

Enter the value obtained from the lux meter and the light sensor reading. Then, press the Set button.

The Reset button clears the calibration, allowing the use of the light sensor value without calibration.

✕

Enter the measured lux level and sensor reading value for 'Input 1-00 Light'.

500

519

Set

Reset

4.5.14 Addition of DALI devices

The button “+” is used to search for non-commissioned devices.

Channel 1 / Scan

[Devices](#)
[Groups](#)
[Scenes](#)
+

Unassigned (2)
Search

Scan
Clear
Auto Assign
Apply Assignment

Device	S.A.	Type	Status	Action
<input type="text" value="Unassigned"/>	3	LED	0%	On Off Identify
<input type="text" value="Unassigned"/>	63	LED	0%	On Off Identify

4.5.15 Unassigned Devices

After scanning a channel, the page displays the non-commissioned devices found on the network. The buttons allow turning **On**, **Off** and to **Identify** the lamp by cycling it between its minimum and its maximum of intensity.

The **Scan** button allows starting a scan on the DALI channel for unassigned devices.

The **Clear** button allows clearing the list of unassigned devices.

The **Auto Assign** button automatically assigns lamps to a lamp index.

The **Apply Assignment** button assign lamps to a selected lamp index.

4.5.16 Assignment

There are three ways of assigning the DALI devices.

4.5.16.1 Auto Assign

The lamps are automatically assigned to a lamp index.

4.5.16.2 Apply Assignment

The selected assignment is applied.

4.5.16.3 Search

The available lamps can be searched. By pressing the **Search** button next to a lamp, a search by a half-interval search means is launched to find the lamp. Half of the lamps are turned Off, while the other half is turned On, the user must answer **No** or **Yes** if the desired lamp is On. This process is repeated until only the desired lamp is On.

Once the search is complete, the user can enter a name for the lamp and **Apply** the assignment.

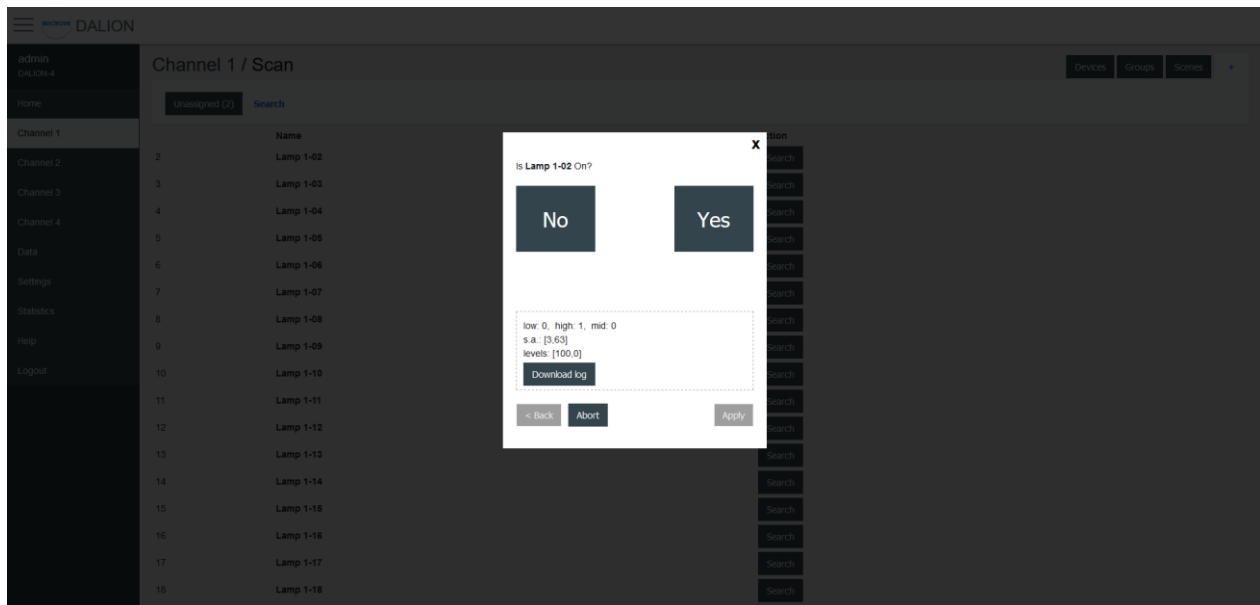

4.6 Data

4.6.1 Data Points

The BACnet objects are listed.

4.6.2 Schedules

The schedules allow to automatically adjust the light intensity at a specific time for the groups, channels and scene controllers.

There are 4 (4 DALI channels model), 1 (1 DALI channel model) schedules of 7 weekdays and each day can execute up to 6 different events. Each schedule can control up to 4 different data points.

4.6.2.1 Schedules Brief

Displays the current values of the schedules and allows to **Enable** or **Disable** them.

Clicking on a schedule row allows to modify its parameters and events.

The screenshot shows the DALION web interface. The top left corner displays the DALION logo and the text 'DALION-4 admin 2020-07-28 09:03:13 DALION'. The main content area is titled 'Data / Schedules' and features an 'Update' button. Below this is a 'Schedules Brief' section containing a table with the following data:

Name	Present Value	State	
Schedule 1-0	0	Enabled	Disable
Schedule 2-0	0	Enabled	Disable
Schedule 3-0	0	Enabled	Disable
Schedule 4-0	0	Enabled	Disable

At the top right of the table, there are two buttons: 'Enable All' and 'Disable All'. The sidebar on the left contains the following menu items: Home, Channel 1, Channel 2, Channel 3, Channel 4, Data (highlighted), Settings, Statistics, Help, and Logout.

4.6.2.2 Schedule Parameters

Allows to modify the parameters of a schedule such as its name and its output data point.

DALION-4
admin
2020-07-26 09:13:20
DALION

- Home
- Channel 1
- Channel 2
- Channel 3
- Channel 4
- Data**
- Settings
- Statistics
- Help
- Logout

Data / Schedules / Schedule 1-0 / Parameters

Parameters	
Name	<input type="text" value="Schedule 1-0"/>
Schedule Output - 0	<input type="text" value="Channel 1 (Channel 1)"/> ▾
Schedule Output - 1	<input type="text" value=""/> ▾
Schedule Output - 2	<input type="text" value=""/> ▾
Schedule Output - 3	<input type="text" value=""/> ▾
Effective Period Start	<input type="text" value="2000-01-01"/> <small>yyyy-mm-dd</small>
Effective Period End	<input type="text" value="2037-12-31"/> <small>yyyy-mm-dd</small>
Priority For Writing	<input type="text" value="8"/> ▾

Name	Unit	Minimum	Maximum	Default	Description
Name	String		32 characters		Name of the schedule
Output Type	Choice				The type of output
Schedule Output 1	Data Point				Data point where the schedule writes
Schedule Output 2	Data Point				Data point where the schedule writes
Schedule Output 3	Data Point				Data point where the schedule writes
Schedule Output 4	Data Point				Data point where the schedule writes
Effective Period Start	Date				First date on which the schedule is in effect
Effective Period End	Date				Last date on which the schedule is in effect
Priority For Writing	Number	1	16	8	Priority used by the schedule when writing
Schedule Default	Number				Default value of the schedule
BACnet Object	String				BACnet object identifier of the schedule

4.6.2.2.1 Output Type

4.6.2.2.1.1 Group, Channel

Allows sending command to a group or channel.

4.6.2.2.1.2 Commander

Allows sending command to a single commander.

4.6.2.2.1.3 Commanders

Allows sending command to a commander.

4.6.2.3 Weekly Schedule

Displays the scheduled events of the schedule.

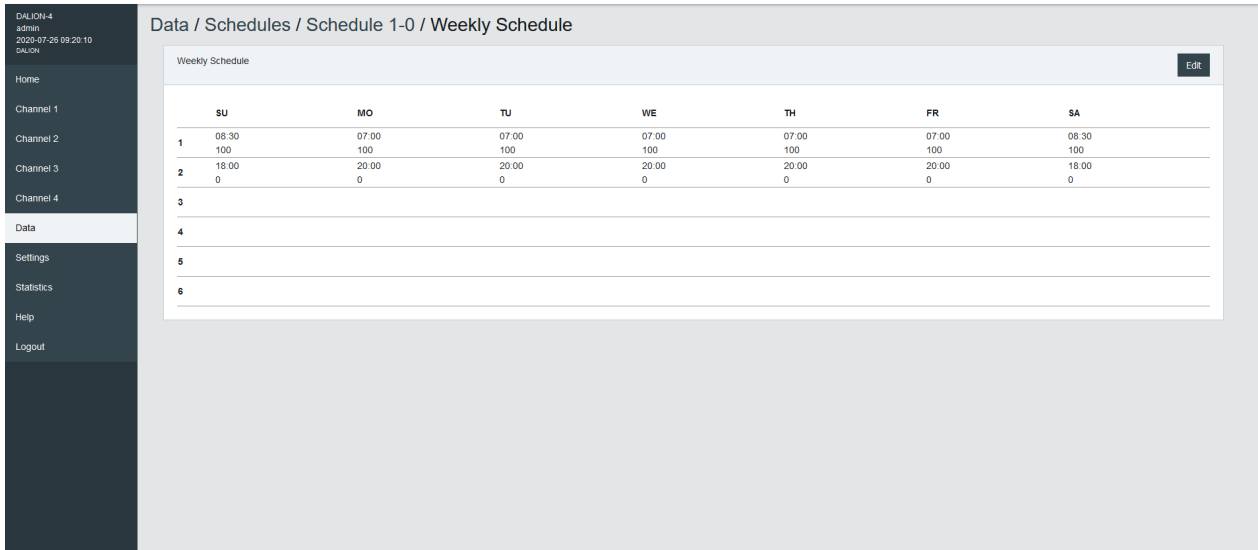

4.6.2.4 Weekly Schedule Edit

Allows modifying the schedule events.

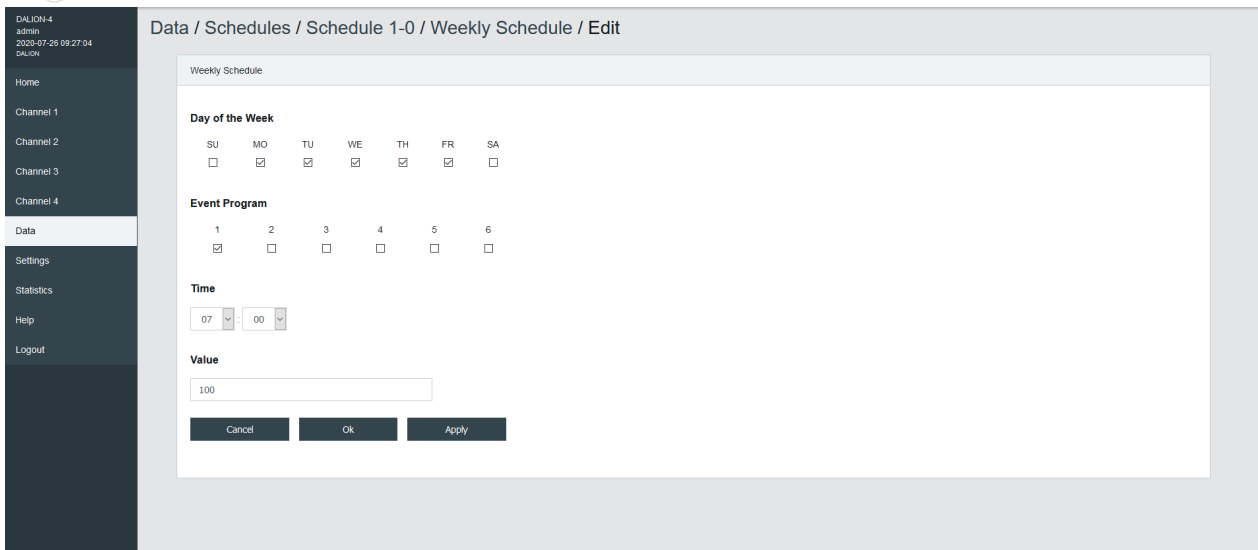

4.6.2.4.1 Day of the Week

Allows selecting the days of the week to modify. Several days can be modified at the same time.

4.6.2.4.2 Event Program

Allows selecting the event program to modify.

4.6.2.4.3 Type

The type of event time.

Type	Description
Time	Fixed time
Sunrise	Astronomical sunrise time
Sunset	Astronomical sunset time

4.6.2.4.4 Time

The time of the event.

By Selecting – : – the events corresponding to the selected **Day of the Week** and **Event Program** will be deleted.

4.6.2.4.5 Offset

For astronomical time allows for an offset of 120 minutes before or after the astronomical time.

4.6.2.4.6 Earliest Time

For astronomical time allows limiting the earliest time that the event can occur.

4.6.2.4.7 Execute Earliest

For astronomical time allows executing the event if it were to occur before the Earliest Time.

4.6.2.4.8 Latest Time

For astronomical time allows limiting the latest time that the event can occur.

4.6.2.4.9 Execute Latest

For astronomical time allows executing the event if it were to occur after the Latest Time.

4.6.2.4.10 Value

The value written by the schedule at the specified time.

4.6.2.4.11 Buttons

The **Ok** button applies the modification of the schedule events and returns to the Weekly Schedule page.

The button **Apply** applies the modification but remains on the same page to allow the entry of more events. The button **Cancel** returns to the Weekly Schedule page without modifying the events.

4.6.3 Room Light Control

The Room Light Control allow to automatically adjust the light intensity depending of external inputs such as occupancy, presence and light sensors.

4.6.3.1 Room Light Control List

Lists all the available Room Light Control. It also indicates the current states of the occupancy, light sensors and outputs.

Clicking on a Room Light Control row allows to modify its parameters.

Room Light Control				
Name	Light	Occupancy	Output	Output 2
RLC 01	Input 1-00 Light 0 lux	Input 1-00 Occupancy	Channel 1 (Channel 1) 100 %	
RLC 02				
RLC 03				
RLC 04				
RLC 05				
RLC 06				
RLC 07				
RLC 08				
RLC 09				
RLC 10				
RLC 11				
RLC 12				
RLC 13				
RLC 14				
RLC 15				
RLC 16				
RLC 17				
RLC 18				
RLC 19				

4.6.3.2 Room Light Control Parameters

Allows to modify the parameters of a Room Light Control such as its name, its timings and its output data points.

Refer to the associated BACnet object for further details.

DALION-4
admin
2021-10-10 12:19:43
DALION

- Home
- Channel 1
- Channel 2
- Channel 3
- Channel 4
- Data
- Settings
- Statistics
- Help
- Logout

Room Light Control / RLC 01

Parameters

Enabled

Parameters

Name: RLC 01

Mode: Enabled

Write Priority: 8

Occupancy

Occupied Command: Direct Value

Occupied Intensity (%) or Scene Number: 90

Unoccupied Command: Direct Value

Unoccupied Intensity (%) or Scene Number: 0

Sensors

Light Sensor

Light Sensors - 1: Input 1-00 Light (Channel 1 / Light Sensor 00)

Occupancy Sensors

Occupancy Sensors - 1: Input 1-00 Occupancy (Channel 1 / Occupancy Sens

Occupancy Sensors - 2

Occupancy Sensors - 3

Occupancy Sensors - 4

Occupancy Sensors - 5

Occupancy Sensors - 6

Occupancy Sensors - 7

Occupancy Sensors - 8

Outputs

Primary outputs.

Output - 1: Channel 1 (Channel 1)

Output - 2

Output - 3

Output - 4

Save

Outputs 2

Secondary outputs associated with Lamp 2 configuration.

Output 2 - 1

Output 2 - 2

Output 2 - 3

Output 2 - 4

Save

4.6.3.2.1 Parameters

Name	Unit	Limit	Default	Description
Name	String	8 characters	RLC NN, where NN is the number of the Room Light Control	Name of the Room Light Control.
Mode	Choice	Enabled, Disabled	Disabled	Allows to enable and disable the Room Light Control.
Write Priority	Number	1-16	8	Priority for writing to the outputs.

4.6.3.2.2 Occupancy

Name	Unit	Limit	Default	Description
Occupied Command	Choice	Disabled, Direct Value, Max Level, Off, Min Level, Recall Scene, Start Daylight Harvesting, Stop Daylight Harvesting	Disabled	Command executed when entering the occupied state.
Occupied Intensity (%) or Scene Number	Percent or Number	0-100% or 0-15 Scene Number	0	The value for the Occupied Command.
Unoccupied Command	Choice	Disabled, Direct Value, Max Level, Off, Min Level, Recall Scene, Start Daylight Harvesting, Stop Daylight Harvesting	Disabled	Command executed when entering the unoccupied state.
Unoccupied Intensity (%) or Scene Number	Percent or Number	0-100% or 0-15 Scene Number	0	The value for the Unoccupied Command.
Warning Command	Choice	Disabled, Direct Value, Max Level, Off, Min Level, Recall Scene, Start Daylight Harvesting, Stop Daylight Harvesting	Disabled	Command executed when entering the warning state.
Warning Intensity (%)	Percent or	0-100% or 0-15 Scene Number	0	The value for the Warning Command.

or Scene Number	Number			
Warning Time	Seconds	0 - 2 400	0 (disabled)	The warning time.
Hold Time	Seconds	0 - 2 400	0 (disabled)	Hold time for occupancy state.
Ignore Time	Seconds	0 - 2 400	0 (disabled)	Time where the occupation update is ignored after the lamp goes Off.
Override Time	Seconds	0 - 72 000	0	Time where the unoccupied state is temporarily overwritten by the occupied state.
Occupied Mode Command Enable	Choice	No Command, Unoccupied Command, Occupied Command, Unoccupied and Occupied Command	Unoccupied and Occupied Command	It allows enabling and disabling the execution of the occupancy command when Occupied_Mode is modified.

4.6.3.2.3 Daylight Harvesting

Name	Unit	Limit	Default	Description
Setpoint Unoccupied	Number	0 - 65 534	0	Setpoint unoccupied for the illumination level.
Setpoint Occupied	Number	0 - 65 534	0	Setpoint occupied for the illumination level.
Deadband	Number	0 - 65 534	20	Deadband for the current setpoint.
Step Value	Percent	0 - 100	4	Maximum step to approach the illumination setpoint in percentage.
Minimum Intensity	Percent	0 - 100	0	Minimum intensity.
Maximum Intensity	Percent	0 - 100	0	Maximum intensity.
Delay On	Seconds	0 - 240	0	Delay for switching On the lamp.
Delay Off	Seconds	0 - 240	0	Delay for switching Off the lamp.
Lamp 2 Offset	Percent	0 - 100	0	Lamp 2 Offset.
Lamp 2 Limit	Percent	0 - 100	0	Lamp 2 Limit.

4.6.3.2.4 Light Sensor

Selection of the light sensor for daylight harvesting.

4.6.3.2.5 Occupancy Sensor

Selection of the occupancy sensors for occupied state.

4.6.3.2.6 Outputs

Selection of the primary outputs.

4.6.3.2.7 Outputs 2

Selection of the secondary outputs.

4.6.3.3 Room Light Control States

Accessed via the Room Light Control list with the States button, displays the internal states and timers of the Room Light Control. It provides valuable information on the operations and internal states of Room Light Control, making it easier to understand their functioning.

4.6.3.3.1 Name

Name of the Room Light Control.

4.6.3.3.2 States

Value	Description
DL	Daylight Harvesting is currently active
OC	Currently occupied
OA	Override is currently active
OM	Occupied Mode is occupied

4.6.3.3.3 Flags

Internal information.

4.6.3.3.4 Occupancy State

Value	Description
Unknown	Unknown state, this may be due to an unconfigured Room Light Control
Unoccupied	Unoccupied
Unoccupied - Wait Ignore Time	The occupancy sensors Ignore Time is currently counting
Occupied	Occupied
Occupied - Wait Hold Time	The occupancy sensors Hold Time is currently counting
Occupied - Wait Warning Time	Warning command was executed and Warning Time is currently counting

4.6.3.3.5 Occupancy Timer (s)

Increments, in seconds, up to the configured parameter value.

4.6.3.3.6 Light Integrator

Internal value of the Daylight Harvesting control.

4.6.3.3.7 Light Prev. Error

Internal value of the Daylight Harvesting control.

4.6.3.3.8 Light Diff.

Internal value of the Daylight Harvesting control.

4.6.3.3.9 Light Prev. Meas.

Internal value of the Daylight Harvesting control.

4.6.3.3.10 Light Out.

Internal value of the Daylight Harvesting control.

4.6.3.3.11 Override Timer (s)

Increments, in seconds, up to the configured parameter value.

4.6.4 Energy Usage Accumulated

It represents the accumulated energy consumption in watt-hours for the lamps. The values are the result of a calculation based on the configured nominal power.

Data / Energy Usage Update

It represents the accumulated energy consumption in watt-hours for the lamps.
The values are the result of a calculation based on the configured nominal power.

Data Points					Reset All	Export	Print
Channel ↓	Index ↓	Name ↓	Energy (Wh) ↓	Nominal Power ↓			
0	0	Lamp 1-00	3398.7	111		Reset	
0	1	Lamp 1-01	3398.7	111		Reset	
0	2	Lamp 1-02	3770.9	123		Reset	
0	3	Lamp 1-03	316.5	30		Reset	

4.6.4.1 Data Points List

It lists the accumulated energy for each configured lamp. Clicking on a column name allows sorting the table.

4.6.4.2 Columns

4.6.4.2.1 Channel

The lamp channel number, 1 to 4.

4.6.4.2.2 Index

The lamp index number, 0 to 63.

4.6.4.2.3 Name

The lamp name.

4.6.4.2.4 Energy (Wh)

The accumulated energy.

4.6.4.2.5 Nominal Power

The configured nominal power.

4.6.4.2.6 Change Time

The last time when the accumulated energy was saved.

4.6.4.2.7 Reset Time

The last time when the accumulated energy was reset or directly written.

4.6.4.3 Buttons

4.6.4.3.1 Print

It allows printing the accumulated energy consumption values.

4.6.4.3.2 Export

It allows downloading accumulated energy consumption values in a TSV (tab-separated values) file.

4.6.4.3.3 Reset All

Reset to zero the accumulated energy consumption for all lamps.

4.6.4.3.4 Reset

Reset to zero the accumulated energy consumption for the lamp.

4.7 Statistics

Many counters are available to help with the diagnostic of network problems for the DALI, BACnet and Ethernet interfaces.

4.7.1 System Log

Displays the system log file that records certain system events.

4.7.2 DALI

Many counters are available to help with the diagnostic of DALI related problems.

The screenshot shows the 'Statistics / DALI' page in the DALI-ON interface. The page has a dark sidebar on the left with navigation options: admin, DALI-CH-4, Home, Channel 1, Channel 2, Channel 3, Channel 4, Settings, Statistics (highlighted), Help, and Logout. The main content area has a title 'Statistics / DALI' and two buttons: 'Update' and 'Clear'. Below the buttons is a table titled 'DALI' with the following data:

DALI counters	
DALI 1	
Tx packets	978
Rx packets	422
Tx No Answer	556
DALI 2	
Tx packets	0
Rx packets	0
Tx No Answer	0
DALI 3	
Tx packets	0
Rx packets	0
Tx No Answer	0
DALI 4	
Tx packets	0
Rx packets	0
Tx No Answer	0

Name	Description
Tx Packets	The number of packets transmitted
Rx Packets	The number of packets received
Tx No Answer	The number of transmission with a missing answer
Rx Bit Timing Violation	The number of bit timing violation detected
Tx Collision Avoidance	The number of collisions avoided
Tx Collision Detection	The number of collisions detected
Tx Timeout Override	The number of canceled transmissions

4.7.3 DALI protocol analyzer

The analyzer allows network troubleshooting and analysis of the DALI communication protocol. It displays in real time the received and transmitted DALI packets. It is possible to **Pause**, **Clear** or **Save** the data to the computer with the buttons.

The screenshot shows the 'Statistics / DA Analyzer / 1' page in the DALI-ON application. It features a sidebar on the left with navigation links: admin, DALI-ON-4, Home, Channel 1, Channel 2, Channel 3, Channel 4, Settings, Statistics (highlighted), Help, and Logout. The main content area has a header with 'Pause', 'Clear', and 'Save' buttons. Below this is a table titled 'DALI Analyzer' with the following data:

Time	Type	Hex	Address	Command
949916400	TXFW	5105	40	RECALL MAX LEVEL
949916392	RXBW	FE		254 (FE)
949916392	TXFW	7FA0	63	QUERY ACTUAL LEVEL
949916392	RXBW	84		132 (84)
949916392	TXFW	7F90	63	QUERY STATUS
949916374	RXBW	FE		254 (FE)
949916373	TXFW	51A0	40	QUERY ACTUAL LEVEL
949916373	RXBW	84		132 (84)
949916373	TXFW	5190	40	QUERY STATUS
949916343	RXBW	FE		254 (FE)
949916343	TXFW	7FA0	63	QUERY ACTUAL LEVEL
949916343	RXBW	84		132 (84)
949916343	TXFW	7F90	63	QUERY STATUS
949916326	RXBW	FE		254 (FE)
949916326	TXFW	51A0	40	QUERY ACTUAL LEVEL

Name	Description
Time	The time the packet was received or transmitted
Type	The packet type
Hex	Hexadecimal raw data of the packet
Address	The packet destination address
Command	The command

4.7.3.1 Packet Type

Name	Description
TXFW	Transmission of a forward frame
TXBW	Transmission of a backward frame
RXFW	Reception of a forward frame
RXBW	Reception of a backward frame

4.7.4 BACnet/IP

Many counters are available to help with the diagnostic of BACnet related problems.

Name	Description
Tx Packets	The number of packets transmitted
Rx Packets	The number of packets received
Dropped Packets	The number of dropped packets
BVLC Last Result	The last result of BVLC
Invoke ID Unavailable	The number of time a new Invoke ID was unavailable
Invoke ID Failed	The number of failed Invoike ID
Task Time	Timing of the BACnet task
Task Time Error Count	The number of BACnet task timing errors
Last Task Time Error	The Last BACnet task timing error

4.7.5 BACnet Active COV Subscriptions

Displays the list of currently active COV-B subscriptions.

4.7.6 IP

Many counters are available to help with the diagnostic of problems with the IP (Internet Protocol) communication stack.

4.7.7 TCP

Many counters are available to help with the diagnostic of problems with the TCP (Transmission Control Protocol) communication stack.

4.7.8 UDP

Many counters are available to help with the diagnostic of problems with the UDP (User Datagram Protocol) communication stack.

4.7.9 ARP

Many counters are available to help with the diagnostic of problems with the ARP (Address Resolution Protocol) communication stack.

4.7.10 ICMP

Many counters are available to help with the diagnostic of problems with the ICMP (Internet Control Message Protocol) communication stack.

4.7.11 ARP Table

This page displays the current ARP (Address Resolution Protocol) cache where IP addresses are associated with Ethernet MAC addresses.

4.7.12 IP Memory

This page displays the current memory usage of the IP stack.

4.7.13 Ethernet

This page displays the current value of some Ethernet registers.

4.7.14 General

This page displays general counters and memory usage.

4.7.15 System Tasks

This page displays the task usage.

4.7.16 File System

This page displays the file system usage.

5 BACnet Interface

DALI's channels, groups, lamps, and scenes are accessible through BACnet standard objects such as Analog Output, Analog Input, Multi-State Output, etc. The light sensors and occupancy sensors are also accessible via objects of the Analog Input and Binary Input types.

5.1 Device Object

List of available properties for this object.

Property Identifier	Property ID	Property Datatype	Conformance Code
Object_Identifier	75	BACnetObjectIdentifier	W
Object_Name	77	CharacterString	W
Object_Type	79	BACnetObjectType	R
System_Status	112	BACnetDeviceStatus	R
Vendor_Name	121	CharacterString	R
Vendor_Identifier	120	Unsigned16	R
Model_Name	70	CharacterString	R
Firmware_Revision	44	CharacterString	R
Application_Software_Version	12	CharacterString	R
Location	58	CharacterString	W
Description	28	CharacterString	W
Protocol_Version	98	Unsigned	R
Protocol_Revision	139	Unsigned	R
Protocol_Services_Supported	97	BACnetServicesSupported	R
Protocol_Object_Types_Supported	96	BACnetObjectTypesSupported	R
Object_List	76	BACnetARRAY[N] of BACnetObjectIdentifier	R
Max_APDU_Length_Accepted	62	Unsigned	R
Segmentation_Supported	107	BACnetSegmentation	R
Local_Time	57	Time	R
Local_Date	56	Date	R
UTC_Offset	119	INTEGER	R
Daylight_Savings_Status	24	BOOLEAN	R
APDU_Segment_Timeout	10	Unsigned	R
APDU_Timeout	11	Unsigned	W
Number_Of_APDU_Retries	73	Unsigned	W
Device_Address_Binding	30	BACnetLIST of BACnetAddressBinding	R
Database_Revision	155	Unsigned	R
Active_COV_Subscriptions	152	BACnetLIST of BACnetCOVSubscription	R
Last_Restart_Reason	196	BACnetRestartReason	R
Time_Of_Device_Restart	203	BACnetTimeStamp	R

Restart_Notification_Recipients	202	BACnetLIST of BACnetRecipient	R
Serial_Number	372	CharacterString	R
Property_List	371	BACnetARRAY[N] of BACnetPropertyIdentifier	R
System_RTC_Temperature	922	REAL	R
System_Uptime	928	Unsigned	R

5.1.1.1 *System_RTC_Temperature*

The internal temperature of the DALION in degree Celsius.

5.1.1.2 *System_Uptime*

The number of seconds since the last boot up of the DALION.

5.2 Network Port Object

List of available properties for this object.

Property Identifier	Property ID	Property Datatype	Conformance Code
Object_Identifier	75	BACnetObjectIdentifier	R
Object_Name	77	CharacterString	R
Object_Type	79	BACnetObjectType	R
Status_Flags	111	BACnetStatusFlags	R
Reliability	103	BACnetReliability	R
Out_Of_Service	81	BOOLEAN	R
Network_Type	427	BACnetNetworkType	R
Protocol_Level	482	BACnetProtocolLevel	R
Changes_Pending	416	BOOLEAN	R
Network_Number	425	Unsigned16	R
Network_Number_Quality	426	BACnetNetworkNumberQuality	R
APDU_Length	399	Unsigned	R
MAC_Address	423	OCTET STRING	R
BACnet_IP_Mode	408	BACnetIPMode	R
IP_Address	400	OCTET STRING	R
BACnet_IP_UDP_Port	412	Unsigned16	R
IP_Subnet_Mask	411	OCTET STRING	R
IP_Default_Gateway	401	OCTET STRING	R
IP_DNS_Server	406	BACnetARRAY[N] of OCTET STRING	R
FD_BBMD_Address	418	BACnetHostNPort	R
FD_Subscription_Lifetime	419	Unsigned16	R
IP_DHCP_Enable	402	BOOLEAN	R
IP_DHCP_Lease_Time	403	Unsigned	R
IP_DHCP_Lease_Time_Remaining	404	Unsigned	R
IP_DHCP_Server	405	OCTET STRING	R

5.3 Analog Output Object - Control of Lamp, Group, and Channel

To control the intensity of the lamps, use the Analog Output objects. Lamps parameters can also be modified with these objects.

5.3.1 Lamp

List of available properties for these objects.

Property Identifier	Property ID	Property Datatype	Conformance Code
Object_Identifier	75	BACnetObjectIdentifier	R
Object_Name	77	CharacterString	W
Object_Type	79	BACnetObjectType	R
Present_Value	85	REAL	W
Description	28	CharacterString	R
Device_Type	31	CharacterString	R
Status_Flags	111	BACnetStatusFlags	R
Event_State	36	BACnetEventState	R
Reliability	103	BACnetReliability	R
Out_Of_Service	81	BOOLEAN	W
Units	117	BACnetEngineeringUnits	R
Min_Pres_Value	69	REAL	R
Max_Pres_Value	65	REAL	W
Priority_Array	87	BACnetPriorityArray	R
Relinquish_Default	104	REAL	R
Current_Command_Priority	431	BACnetOptionalUnsigned	R
Power_On_Level	512	REAL	W
System_Failure_Level	513	REAL	W
Fade_Time	514	REAL	W
Ramp_Rate	515	REAL	W
Min_Level	516	REAL	W
Groups	517	BIT STRING	W
Nominal_Power	518	REAL	W
Dim_Mode	520	Enumerated	W
Run_Hours	527	Unsigned	R
Run_Hours_Reset_Time	528	Unsigned	R
Colour_Temp	567	REAL	W
Command	900	Unsigned	W
Device_Type_Supported	925	BIT STRING	R
Energy_Usage_Accumulated	926	REAL	W
Emergency_Time_Until_Next_Function_Test	1010	Unsigned	W

Emergency_Time_Until_Next_Duration_Test	1011	Unsigned	W
Emergency_Battery_Charge	1012	REAL	R
Emergency_Duration_Test_Result	1013	Unsigned	R
Emergency_Emergency_Mode	1014	BIT STRING	R
Emergency_Failure_Status	1015	BIT STRING	R
Emergency_Emergency_Status	1016	BIT STRING	R
Emergency_Emergency_Level	1020	REAL	W
Emergency_Emergency_Minimum_Level	1021	REAL	R
Emergency_Emergency_Maximum_Level	1022	REAL	R
Emergency_Prolong	1023	Unsigned	W
Emergency_Function_Test_Interval_Time	1026	Unsigned	W
Emergency_Duration_Test_Interval_Time	1027	Unsigned	W
Emergency_Test_Execution_Timeout	1028	Unsigned	W
Emergency_Lamp_Emergency_Time	1029	Unsigned	R
Emergency_Lamp_Total_Operation_Time	1030	Unsigned	R
Emergency_Rated_Duration	1031	Unsigned	R
Emergency_Features	1032	BIT STRING	R
Dimming_Curve	6000	Enumerated	W
Colour_Type	8000	Enumerated	W
Colour_XYC_X	8010	REAL	W
Colour_XYC_Y	8011	REAL	W
Colour_TC_TC	8020	REAL	W
Colour_PN_P0	8030	REAL	W
Colour_PN_P1	8031	REAL	W
Colour_PN_P2	8032	REAL	W
Colour_PN_P3	8033	REAL	W
Colour_PN_P4	8034	REAL	W
Colour_PN_P5	8035	REAL	W
Colour_RGBWAF_RED	8040	REAL	W
Colour_RGBWAF_GREEN	8041	REAL	W
Colour_RGBWAF_BLUE	8042	REAL	W
Colour_RGBWAF_WHITE	8043	REAL	W
Colour_RGBWAF_AMBER	8044	REAL	W

Colour_RGBWAF_FREECOLOUR

8045

REAL

W

5.3.2 Group

List of available properties for these objects.

Property Identifier	Property ID	Property Datatype	Conformance Code
Object_Identifier	75	BACnetObjectIdentifier	R
Object_Name	77	CharacterString	W
Object_Type	79	BACnetObjectType	R
Present_Value	85	REAL	W
Description	28	CharacterString	R
Device_Type	31	CharacterString	R
Status_Flags	111	BACnetStatusFlags	R
Event_State	36	BACnetEventState	R
Reliability	103	BACnetReliability	R
Out_Of_Service	81	BOOLEAN	W
Units	117	BACnetEngineeringUnits	R
Min_Pres_Value	69	REAL	R
Max_Pres_Value	65	REAL	W
Priority_Array	87	BACnetPriorityArray	R
Relinquish_Default	104	REAL	R
Current_Command_Priority	431	BACnetOptionalUnsigned	R
Power_On_Level	512	REAL	W
System_Failure_Level	513	REAL	W
Fade_Time	514	REAL	W
Ramp_Rate	515	REAL	W
Min_Level	516	REAL	W
Nominal_Power	518	REAL	W
Dim_Mode	520	Enumerated	W
Colour_Temp	567	REAL	W
Command	900	Unsigned	W
Energy_Usage_Accumulated	926	REAL	W
Dimming_Curve	6000	Enumerated	W
Colour_Type	8000	Enumerated	W
Colour_XYC_X	8010	REAL	W
Colour_XYC_Y	8011	REAL	W
Colour_TC_TC	8020	REAL	W
Colour_PN_P0	8030	REAL	W
Colour_PN_P1	8031	REAL	W

Colour_PN_P2	8032	REAL	W
Colour_PN_P3	8033	REAL	W
Colour_PN_P4	8034	REAL	W
Colour_PN_P5	8035	REAL	W
Colour_RGBWAF_RED	8040	REAL	W
Colour_RGBWAF_GREEN	8041	REAL	W
Colour_RGBWAF_BLUE	8042	REAL	W
Colour_RGBWAF_WHITE	8043	REAL	W
Colour_RGBWAF_AMBER	8044	REAL	W
Colour_RGBWAF_FREECOLOUR	8045	REAL	W

5.3.3 Channel

List of available properties for these objects.

Property Identifier	Property ID	Property Datatype	Conformance Code
Object_Identifier	75	BACnetObjectIdentifier	R
Object_Name	77	CharacterString	W
Object_Type	79	BACnetObjectType	R
Present_Value	85	REAL	W
Description	28	CharacterString	R
Device_Type	31	CharacterString	R
Status_Flags	111	BACnetStatusFlags	R
Event_State	36	BACnetEventState	R
Reliability	103	BACnetReliability	R
Out_Of_Service	81	BOOLEAN	W
Units	117	BACnetEngineeringUnits	R
Min_Pres_Value	69	REAL	R
Max_Pres_Value	65	REAL	W
Priority_Array	87	BACnetPriorityArray	R
Relinquish_Default	104	REAL	R
Current_Command_Priority	431	BACnetOptionalUnsigned	R
Power_On_Level	512	REAL	W
System_Failure_Level	513	REAL	W
Fade_Time	514	REAL	W
Ramp_Rate	515	REAL	W
Min_Level	516	REAL	W
Nominal_Power	518	REAL	W
Dim_Mode	520	Enumerated	W
Colour_Temp	567	REAL	W
Command	900	Unsigned	W
Energy_Usage_Accumulated	926	REAL	W
Dimming_Curve	6000	Enumerated	W
Colour_Type	8000	Enumerated	W
Colour_XYC_X	8010	REAL	W
Colour_XYC_Y	8011	REAL	W
Colour_TC_TC	8020	REAL	W
Colour_PN_PO	8030	REAL	W

Colour_PN_P1	8031	REAL	W
Colour_PN_P2	8032	REAL	W
Colour_PN_P3	8033	REAL	W
Colour_PN_P4	8034	REAL	W
Colour_PN_P5	8035	REAL	W
Colour_RGBWAF_RED	8040	REAL	W
Colour_RGBWAF_GREEN	8041	REAL	W
Colour_RGBWAF_BLUE	8042	REAL	W
Colour_RGBWAF_WHITE	8043	REAL	W
Colour_RGBWAF_AMBER	8044	REAL	W
Colour_RGBWAF_FREECOLOUR	8045	REAL	W
Network_Mode	923	Unsigned	W
Network_Command_Repeat_Count	924	Unsigned	W

5.3.3.1 Object_Identifier

The object instance number is represented as TCLL.

- “T” is the type of object as follows, 0 for DALI lamps, 1 for DALI groups and 2 for DALI channels.
- “C” represents the DALI channel number, 0, 1, 2, or 3.
- “LL” represents for lamp objects, numbers 00-63, for group objects, numbers 00-15 and for channel objects, number 00.

5.3.3.2 Object_Name

The name of the DALI lamp, group or channel.

5.3.3.3 Object_Type

ANALOG_OUTPUT (1).

5.3.3.4 Present_Value

The light intensity in percentages for the DALI lamp, group or channel.

5.3.3.5 Description

A description of the DALI lamp, group or channel.

5.3.3.6 Device_Type

- For lamp objects, it is **DALI lamp**.
- For group objects, it is **DALI group**.
- For channel objects, it is **DALI channel**.

5.3.3.7 *Status_Flags*

This property indicates the general “reliability” of the object.

5.3.3.8 *Reliability*

This property indicates whether the operation of the DALI output is reliable. The values are as follows:

- NO_FAULT_DETECTED (0) - No fault has been detected.
- NO_OUTPUT (6) - No DALI device is connected to the output object.
- COMMUNICATION_FAILURE (12) - DALI device is offline.
- UNRELIABLE_OTHER (7) - An error has been reported by the DALI lamp.

5.3.3.9 *Out_Of_Service*

This property indicates whether the physical device represented by the object is in service.

5.3.3.10 *Units*

The unit for the Present_Value is percent.

5.3.3.11 *Min_Pres_Value*

The minimum value is always zero (0). It represents the lowest value for the property Present_Value.

5.3.3.12 *Max_Pres_Value*

For lamp objects, this is the DALI variable “MAX LEVEL” of the lamp. For Group and Channel objects, the value is always 100.

5.3.3.13 *Priority_Array*

This property is a read-only array of prioritized values.

5.3.3.14 *Relinquish_Default*

It is the default value used for the Present_Value property when all command priority values in the Priority_Array property have a NULL value.

5.3.3.15 *Power_On_Level*

It represents the DALI variable “POWER ON LEVEL” of the DALI lamp in percentages. A value of NaN represents the DALI “MASK” value. It is writable for lamps, groups and channels. For groups and channels, it always read as NaN.

5.3.3.16 *System_Failure_Level*

It represents the DALI variable “SYSTEM FAILURE LEVEL” of the DALI lamp in percentages. A value of NaN represents the DALI “MASK” value. It is writable for lamps, groups and channels. For groups and channels, it always read as NaN.

5.3.3.17 *Fade_Time*

Represents the DALI variable “FADE TIME” in seconds for the DALI lamp. It is writable for lamps, groups and channels. For groups and channels, it always read as NaN.

5.3.3.18 *Ramp_Rate*

Represents the DALI variable “FADE RATE” in percent per second for the DALI lamp. It is writable for lamps, groups and channels. For groups and channels, it always read as NaN.

5.3.3.19 *Min_Level*

It represents the DALI variable “MIN LEVEL” of the DALI lamp in percentages. It is writable for lamps, groups and channels. For groups and channels, it always read as NaN.

5.3.3.20 *Groups*

Only available for lamp objects, it represents the DALI variables “GROUP_0_8” and “GROUP_9_15” concatenated in a 16 bit.

5.3.3.21 *Nominal_Power*

It represents the nominal power of the DALI lamp. It is writable for lamps, groups and channels. For groups and channels, it always read as NaN.

5.3.3.22 *Dim_Mode*

Indicates if fading (0) or ramping (1) is used when controlling the light intensity with the Present_Value.

5.3.3.23 *Run_Hours*

The number of seconds the lamp was On.

5.3.3.24 *Run_Hours_Reset_Time*

Indicates the last time the Run_Hours was reset.

5.3.3.25 *Colour_Temp*

For DALI Type 8 (DT8) lamps, whose colour control is colour temperature Tc, the current colour in Kelvin (K) can be modified. The objects for lamps, groups and channels can modify the colour temperature of lamps.

5.3.3.26 *Command*

Allows to execute commands on the lamps.

5.3.3.26.1 NO COMMAND (1)

No command is executed.

5.3.3.26.2 GO TO SCENE (2-17)

Recall the scenes 0-15.

5.3.3.26.3 STORE SCENE (18-33)

Store the scenes 0-15.

5.3.3.26.4 REMOVE SCENE (34-49)

Delete the scenes 0-15.

5.3.3.26.5 RESET RUN HOURS (52)

Reset the run hours to zero.

5.3.3.26.6 EMERGENCY FUNCTION TEST START (54)

Start the function test for the lamps of the type “Self-contained emergency lighting (device type 1)”.

5.3.3.26.7 EMERGENCY DURATION TEST START (55)

Start the duration test for the lamps of the type “Self-contained emergency lighting (device type 1)”.

5.3.3.26.8 EMERGENCY TESTS STOP (56)

Stop the current test for the lamps of the type “Self-contained emergency lighting (device type 1)”.

5.3.3.26.9 GROUP ADD (67-82)

Add to the group 0-15.

5.3.3.26.10 GROUP REMOVE (83-98)

Remove from the group 0-15.

5.3.3.26.11 RECALL MIN LEVEL (200)

Recall Min Level.

5.3.3.26.12 RECALL MAX LEVEL (201)

Recall Max Level.

5.3.3.26.13 RECALL LAST LEVEL (202)

Recall Last Level.

5.3.3.26.14 EMERGENCY REST (203)

For the “Self-contained emergency lighting (device type 1)” only, starts the rest mode.

In this mode the lamp is intentionally off when it is powered from the battery.

Refer to the specification IEC 62386-202 for the complete details on the rest mode.

5.3.3.26.15 EMERGENCY INHIBIT (204)

For the “Self-contained emergency lighting (device type 1)” only, starts the inhibit mode.

In this mode the lamp is powered from the mains power supply but it is also prevented for 15 minutes from going into the emergency mode when an event of mains power failure occurs.

Refer to the specification IEC 62386-202 for the complete details on the inhibit mode.

5.3.3.26.16 EMERGENCY RESET INHIBIT (205)

For the “Self-contained emergency lighting (device type 1)” only, cancels the inhibit timer.

Refer to the specification IEC 62386-202 for the complete details on the inhibit mode.

5.3.3.26.17 EMERGENCY RESET FUNCTION TEST DONE FLAG (206)

For the “Self-contained emergency lighting (device type 1)” only, resets the function test done flag.

Refer to the specification IEC 62386-202 for the complete details on this command.

5.3.3.26.18 EMERGENCY RESET DURATION TEST DONE FLAG (207)

For the “Self-contained emergency lighting (device type 1)” only, resets the duration test done flag.

Refer to the specification IEC 62386-202 for the complete details on this command.

5.3.3.26.19 EMERGENCY START IDENTIFICATION (208)

For the “Self-contained emergency lighting (device type 1)” only, starts the identification.

Refer to the specification IEC 62386-202 for the complete details on this command.

5.3.3.27 *Energy_Usage_Accumulated*

It represents the accumulated energy consumption in watt-hours for the DALI lamp. This value is the result of a calculation based on the Nominal_Power property. It is writable for lamps, groups and channels. For groups and channels, it always read as NaN.

5.3.3.28 *Device_Type_Supported*

Indicates the supported DALI types for the physical DALI device connected to the object.

Bit	Name
0	Fluorescent
1	Self-contained emergency
2	Discharge HID
3	Low-voltage halogen
4	Incandescent lamp
5	Conversion to DC voltage
6	LED
7	Switching relay
8	Colour

5.3.3.29 *Emergency_Time_Until_Next_Function_Test*

For the “Self-contained emergency lighting (device type 1)” only, represents the time until the next function test in minutes.

The valid values are from 0 to 983 025 minutes.

DALI lamps calculate this value in 15 minutes intervals.

5.3.3.30 *Emergency_Time_Until_Next_Duration_Test*

For the “Self-contained emergency lighting (device type 1)” only, represents the time until the next duration test in minutes.

The valid values are from 0 to 983 025 minutes.

DALI lamps calculate this value in 15 minutes intervals.

5.3.3.31 *Emergency_Battery_Charge*

For the “Self-contained emergency lighting (device type 1)” only, represents the battery charge in percentages.

The valid values are from 0 to 100 percent and a value of NaN represents the DALI “MASK” value. “MASK” means that the lamp cannot perform this functionality.

5.3.3.32 *Emergency_Duration_Test_Result*

For the “Self-contained emergency lighting (device type 1)” only, represents the duration test result in minutes.

The valid values are from 0 to 510 minutes.

5.3.3.33 *Emergency_Emergency_Mode*

For the “Self-contained emergency lighting (device type 1)” only, represents the emergency mode.

Bit	Name	Value
0	reset mode is active	0 = No
1	normal mode is active	0 = No
2	emergency mode is active	0 = No
3	extended emergency mode is active	0 = No
4	function test is in progress	0 = No
5	duration test is in progress	0 = No
6	hardwired inhibit is active	0 = Not active / not present
7	hardwired switch is on	0 = Off

5.3.3.34 *Emergency_Failure_Status*

For the “Self-contained emergency lighting (device type 1)” only, represents the failure status.

Bit	Name	Value
0	circuit failure	0 = No
1	battery duration failure	0 = No
2	battery failure	0 = No
3	emergency lamp failure	0 = No
4	function test maximum delay exceeded	0 = No
5	duration test maximum delay exceeded	0 = No
6	function test failed	0 = No
7	duration test failed	0 = No

5.3.3.35 *Emergency_Emergency_Status*

For the “Self-contained emergency lighting (device type 1)” only, represents the emergency status.

Bit	Name	Value
0	inhibit mode	0 = No
1	function test done and result valid	0 = No
2	duration test done and result valid	0 = No
3	battery fully charged	0 = In progress
4	function test request pending	0 = No
5	duration test request pending	0 = No
6	identification active	0 = No
7	physically selected	0 = No

5.3.3.36 *Emergency_Emergency_Level*

For the “Self-contained emergency lighting (device type 1)” only, represents the emergency level in percentages.

The valid values are from 0 to 100 percent and a value of NaN represents the DALI “MASK” value. “MASK” means that the value is unknown.

5.3.3.37 *Emergency_Emergency_Minimum_Level*

For the “Self-contained emergency lighting (device type 1)” only, represents the emergency minimum level in percentages.

The valid values are from 0 to 100 percent and a value of NaN represents the DALI “MASK” value. “MASK” means that the value is unknown.

5.3.3.38 *Emergency_Emergency_Maximum_Level*

For the “Self-contained emergency lighting (device type 1)” only, represents the emergency maximum level in percentages.

The valid values are from 0 to 100 percent and a value of NaN represents the DALI “MASK” value. “MASK” means that the value is unknown.

5.3.3.39 *Emergency_Prolong*

For the “Self-contained emergency lighting (device type 1)” only, represents the prolong time in seconds.

Valid values are between 0 and 7 650 seconds (127 minutes).

DALI lamps calculate this value in 30 second intervals.

5.3.3.40 *Emergency_Function_Test_Interval_Time*

For the “Self-contained emergency lighting (device type 1)” only, represents the function test interval time in days.

Valid values are between 0 and 255 days. The value 0 means that the automatic testing is not supported.

5.3.3.41 Emergency_Duration_Test_Interval_Time

For the “Self-contained emergency lighting (device type 1)” only, represents the duration test interval time in weeks.

Valid values are between 0 and 97 weeks. The value 0 means that the automatic testing is not supported.

5.3.3.42 Emergency_Test_Execution_Timeout

For the “Self-contained emergency lighting (device type 1)” only, represents the test execution timeout in days.

Valid values are between 0 and 255 days. A value of 0 means a 15 minutes execution timeout.

5.3.3.43 Emergency_Lamp_Emergency_Time

For the “Self-contained emergency lighting (device type 1)” only, represents the lamp emergency time in hours.

The valid values are from 0 to 254 hours and a value of 255 represents the maximum value of 254 hours or more.

5.3.3.44 Emergency_Lamp_Total_Operation_Time

For the “Self-contained emergency lighting (device type 1)” only, represents the lamp total operation time in hours.

The valid values are from 0 to 1 016 hours and a value of 1 020 represents the maximum value of 1 016 hours or more.

5.3.3.45 Emergency_Rated_Duration

For the “Self-contained emergency lighting (device type 1)” only, represents the rated duration.

The valid values are from 0 to 510 minutes.

5.3.3.46 Emergency_Features

For the “Self-contained emergency lighting (device type 1)” only, represents the features information describing the type of lamp.

Bit	Name	Value
0	integral emergency control gear	0 = No
1	maintained control gear	0 = No
2	switched maintained control gear	0 = No
3	auto test capability	0 = No
4	adjustable emergency level	0 = No
5	hardwired inhibit supported	0 = No
6	physical selection supported	0 = No
7	re-light in rest mode supported	0 = No

5.3.3.47 Dimming_Curve

The dimming curve determines how the DALI level should be translated into light output. The standard dimming curve is logarithmic. Some lamps allow modifying to dimming curve between logarithmic and a linear one.

The DALION automatically translates the requested light output of a percentage to the dimming curve configured in the lamp with the following formulas.

Logarithmic

$$\text{Light output}(\textit{level}) = 10^{\frac{\textit{level}-1}{253/3} - 1} \%$$

Linear

$$\text{Light output}(\textit{level}) = \frac{\textit{level}}{254} \times 100 \%$$

It is important to note that sending a dimming command to a group consisting of lamps of different dimming curves may not produce the expected result. Ideally, only group lamps configured with the same dimming curve.

It is recommended to configure the dimming curve before programming the other levels such as scenes, minimum level, maximum level, power on level, etc.

5.3.3.47.1 LOGARITHMIC (1)

Standard logarithmic dimming curve.

5.3.3.47.2 LINEAR (2)

Linear dimming curve.

5.3.3.48 Colour_Type

The current or requested colour control type.

The supported colour types are as follows.

Name	Value
xy-coordinate	1
colour temperature Tc	2
primary N	3
RGBWAF	4

5.3.3.49 Colour_XYC_X

For DALI Type 8 (DT8) lamps, whose colour control is xy-Coordinate, the x-coordinate of the current colour can be modified. The objects for lamps, groups and channels can modify the colour of lamps.

The valid values are from 0 to 65534 and a value of NaN represents the DALI “MASK” value.

The unit of the value is 1 / 65536. Therefore the maximum corresponding x-coordinate is 0.99997.

5.3.3.50 Colour_XYC_Y

For DALI Type 8 (DT8) lamps, whose colour control is xy-Coordinate, the y-coordinate of the current colour can be modified. The objects for lamps, groups and channels can modify the colour of lamps.

The valid values are from 0 to 65534 and a value of NaN represents the DALI “MASK” value.

The unit of the value is 1 / 65536. Therefore the maximum corresponding y-coordinate is 0.99997.

5.3.3.51 Colour_TC_TC

For DALI Type 8 (DT8) lamps, whose colour control is colour temperature Tc, the current colour temperature can be modified. The objects for lamps, groups and channels can modify the colour of lamps.

The valid values are from 1 to 65534 and a value of NaN represents the DALI “MASK” value.

The unit of the value is 1 Mirek. Therefore the minimum value is 1 Mirek (1000000 Kelvin) and the maximum value is 65534 Mirek (15.26 Kelvin).

Mirek = 1 000 000 / [Colour Temperature in Kelvin]

Kelvin = 1 000 000 / [value of Mirek]

5.3.3.52 Colour_PN_PO to Colour_PN_P5

For DALI Type 8 (DT8) lamps, whose colour control is primary N, the current colour can be modified. The objects for lamps, groups and channels can modify the colour of lamps.

The valid values are from 0 to 65534 and a value of NaN represents the DALI “MASK” value.

The unit of the value is $1 / 65536$. Therefore the maximum corresponding primary value is 0.99997.

5.3.3.53 Colour_RGBWAF_RED

For the lamps DALI Type 8 (DT8), whose colour control is RGBWAF, the current red colour can be modified. The objects for lamps, groups and channels can modify lamp colour.

The valid values are from 0 to 254 and a value of NaN represents the DALI “MASK” value.

5.3.3.54 Colour_RGBWAF_GREEN

For the lamps DALI Type 8 (DT8), whose colour control is RGBWAF, the current green colour can be modified. The objects for lamps, groups and channels can modify lamp colour.

The valid values are from 0 to 254 and a value of NaN represents the DALI “MASK” value.

5.3.3.55 Colour_RGBWAF_BLUE

For the lamps DALI Type 8 (DT8), whose colour control is RGBWAF, the current blue colour can be modified. The objects for lamps, groups and channels can modify lamp colour.

The valid values are from 0 to 254 and a value of NaN represents the DALI “MASK” value.

5.3.3.56 Colour_RGBWAF_WHITE

For the lamps DALI Type 8 (DT8), whose colour control is RGBWAF, the current white colour can be modified. The objects for lamps, groups and channels can modify lamp colour.

The valid values are from 0 to 254 and a value of NaN represents the DALI “MASK” value.

5.3.3.57 Colour_RGBWAF_AMBER

For the lamps DALI Type 8 (DT8), whose colour control is RGBWAF, the current amber colour can be modified. The objects for lamps, groups and channels can modify lamp colour.

The valid values are from 0 to 254 and a value of NaN represents the DALI “MASK” value.

5.3.3.58 Colour_RGBWAF_FREECOLOUR

For the lamps DALI Type 8 (DT8), whose colour control is RGBWAF, the current freecolour colour can be modified. The objects for lamps, groups and channels can modify lamp colour.

The valid values are from 0 to 254 and a value of NaN represents the DALI “MASK” value.

5.3.3.59 *Network_Mode*

Name	Value	Description
NORMAL	0	The controller is operating normally.
DISABLE	1	The controller is not authorized to communicate on the DALI channel.

5.3.3.60 *Network_Command_Repeat_Count*

The number of repeats of the DALI commands that affect the light intensity of the lamps.

5.4 Analog Input Object - Feedback of Lamp, Group, and Channel

To obtain the intensity of the lamps, use the Analog Input objects.

5.4.1 Lamp, Group and Channel

List of available properties for these objects.

Property Identifier	Property ID	Property Datatype	Conformance Code
Object_Identifier	75	BACnetObjectIdentifier	R
Object_Name	77	CharacterString	W
Object_Type	79	BACnetObjectType	R
Present_Value	85	REAL	W
Description	28	CharacterString	R
Device_Type	31	CharacterString	R
Status_Flags	111	BACnetStatusFlags	R
Event_State	36	BACnetEventState	R
Reliability	103	BACnetReliability	R
Out_Of_Service	81	BOOLEAN	W
Units	117	BACnetEngineeringUnits	R
Min_Pres_Value	69	REAL	R
Max_Pres_Value	65	REAL	W
COV_Increment	22	REAL	W
Nominal_Power	518	REAL	W
Channel_Battery_Failure	532	BIT STRING	R
Channel_Function_Test_Failure	533	BIT STRING	R
Channel_Duration_Test_Failure	534	BIT STRING	R
Last_Level	906	REAL	R
Device_Type_Supported	925	BIT STRING	R
Energy_Usage_Accumulated	926	REAL	W
Emergency_Battery_Failure	1000	BOOLEAN	R
Emergency_Function_Test_Failure	1001	BOOLEAN	R
Emergency_Duration_Test_Failure	1002	BOOLEAN	R
Colour_Type	8000	Enumerated	R
Colour_XYC_X	8010	REAL	R
Colour_XYC_Y	8011	REAL	R
Colour_TC_TC	8020	REAL	R
Colour_PN_P0	8030	REAL	R
Colour_PN_P1	8031	REAL	R
Colour_PN_P2	8032	REAL	R
Colour_PN_P3	8033	REAL	R

Colour_PN_P4	8034	REAL	R
Colour_PN_P5	8035	REAL	R
Colour_RGBWAF_RED	8040	REAL	R
Colour_RGBWAF_GREEN	8041	REAL	R
Colour_RGBWAF_BLUE	8042	REAL	R
Colour_RGBWAF_WHITE	8043	REAL	R
Colour_RGBWAF_AMBER	8044	REAL	R
Colour_RGBWAF_FREECOLOUR	8045	REAL	R

5.4.1.1 Object_Identifier

The object instance number is the same as the associated Analog Output object and is also represented as TCLK.

- “T” is the type of object as follows, 0 for DALI Lamps, 1 for DALI groups and 2 for DALI channels.
- “C” represents the DALI channel number, 0, 1, 2, or 3.
- “LL” represents for lamp objects, numbers 00-63, for group objects, numbers 00-15 and for channel objects, number 00.

5.4.1.2 Object_Name

The **Object_Name** of the associated Analog Output object of the DALI lamp, group or channel ending with “Feedback”.

5.4.1.3 Object_Type

ANALOG_INPUT (0).

5.4.1.4 Present_Value

The current light intensity as a percentage for the DALI lamps, groups and channels.

5.4.1.5 Description

The **Description** of the associated Analog Output object of the DALI lamp, group or channel ending with “Feedback”.

5.4.1.6 Device_Type

A text description of the physical DALI device connected to the analog output, it is the DALI device type (ex. “**Fluorescent lamps**”, “**Conversion from digital signal into d.c. voltage**”, “**LED modules**”, “**Switching function**”). For group objects, it is “**DALI group**”. For channel objects, it is “**DALI channel**”.

5.4.1.7 Status_Flags

This property indicates the general “reliability” of an analog input object.

5.4.1.8 Reliability

This property indicates whether the operation of the DALI output is reliable. The values are as follows:

- NO_FAULT_DETECTED (0) - No fault has been detected.
- NO_SENSOR (1) - No physical device is connected to the input object.
- COMMUNICATION_FAILURE (12) - DALI device is offline.
- UNRELIABLE_OTHER (7) - A DALI error has been reported by the DALI lamp.

5.4.1.9 *Out_Of_Service*

It indicates whether the physical device that the object represents is in service.

5.4.1.10 *Units*

The unit for the Present_Value is percent.

5.4.1.11 *Min_Pres_Value*

The minimum value is always zero (0). It represents the lowest value for the property Present_Value.

5.4.1.12 *Max_Pres_Value*

The maximum value is always one hundred (100). It represents the highest value for the property Present_Value.

5.4.1.13 *COV_Increment*

This property specifies the minimum change of the Present_Value that issues a COVNotification.

5.4.1.14 *Nominal_Power*

It represents the nominal power of the DALI lamp. It is writable for lamps, groups and channels. For groups and channels, it always read as NaN.

5.4.1.15 *Channel_Battery_Failure*

Only available for channel objects, this property indicates whether a “Self-contained emergency lighting (device type 1)” is reporting a battery failure. Each 64 lamps of the channel are one bit of the 64-bit BIT STRING. When a battery failure is reported by a lamp, its associated bit is set.

5.4.1.16 *Channel_Function_Test_Failure*

Only available for channel objects, this property indicates whether a “Self-contained emergency lighting (device type 1)” is reporting a function test failure. Each 64 lamps of the channel are one bit of the 64-bit BIT STRING. When a function test failure is reported by a lamp, its associated bit is set.

5.4.1.17 *Channel_Duration_Test_Failure*

Only available for channel objects, this property indicates whether a “Self-contained emergency lighting (device type 1)” is reporting a duration test failure. Each 64 lamps of the channel are one bit of the 64-bit BIT STRING. When a duration test failure is reported by a lamp, its associated bit is set.

5.4.1.18 *Last_Level*

It represents the last level value in percentages.

5.4.1.19 *Device_Type_Supported*

Only available for lamp objects, this property indicates the supported DALI types for the physical DALI device connected to the object.

Bit	Name
0	Fluorescent
1	Self contained emergency
2	Discharge HID
3	Low voltage halogen
4	Incandescent lamp
5	Conversion to DC voltage
6	LED
7	Switching relay
8	Colour

5.4.1.20 *Energy_Usage_Accumulated*

It represents the accumulated energy consumption in watt-hours for the DALI lamp. This value is the result of a calculation based on the `Nominal_Power` property. It is writable for lamps, groups and channels. For groups and channels, it always read as NaN.

5.4.1.21 *Emergency_Battery_Failure*

Only available for lamp objects, this property indicates whether a “Self-contained emergency lighting (device type 1)” is reporting a battery failure. When a battery failure is reported by the lamp, the value is true.

5.4.1.22 *Emergency_Function_Test_Failure*

Only available for lamp objects, this property indicates whether a “Self-contained emergency lighting (device type 1)” is reporting a function test failure. When a function test failure is reported by the lamp, the value is true.

5.4.1.23 *Emergency_Duration_Test_Failure*

Only available for lamp objects, this property indicates whether a “Self-contained emergency lighting (device type 1)” is reporting a duration test failure. When a duration test failure is reported by the lamp, the value is true.

5.4.1.24 *Colour_Type*

The current colour control type.

The supported colour types are as follows.

Name	Value
xy-coordinate	1
temperature Tc	2
primary N	3
RGBWAF	4

5.4.1.25 Colour_XYC_X

The current x-coordinate value of DALI Type 8 (DT8) lamps, whose colour control is xy-Coordinate.

The valid values are from 0 to 65534 and a value of NaN represents the DALI “MASK” value.

The unit of the value is 1 / 65536. Therefore the maximum corresponding x-coordinate is 0.99997.

5.4.1.26 Colour_XYC_Y

The current y-coordinate value of DALI Type 8 (DT8) lamps, whose colour control is xy-Coordinate.

The valid values are from 0 to 65534 and a value of NaN represents the DALI “MASK” value.

The unit of the value is 1 / 65536. Therefore the maximum corresponding y-coordinate is 0.99997.

5.4.1.27 Colour_TC_TC

The current colour temperature of DALI Type 8 (DT8) lamps, whose colour control is colour temperature Tc.

The valid values are from 1 to 65534 and a value of NaN represents the DALI “MASK” value.

The unit of the value is 1 Mirek. Therefore the minimum value is 1 Mirek (1000000 Kelvin) and the maximum value is 65534 Mirek (15.26 Kelvin).

Mirek = 1 000 000 / [Colour Temperature in Kelvin]

Kelvin = 1 000 000 / [value of Mirek]

5.4.1.28 Colour_PN_P0 to Colour_PN_P5

The current primary N value of DALI Type 8 (DT8) lamps, whose colour control is primary N.

The valid values are from 0 to 65534 and a value of NaN represents the DALI “MASK” value.

The unit of the value is 1 / 65536. Therefore the maximum corresponding primary value is 0.99997.

5.4.1.29 Colour_RGBWAF_RED

The current red value of DALI Type 8 (DT8) lamps, whose colour control is RGBWAF.

The valid values are from 0 to 254 and a value of NaN represents the DALI “MASK” value.

5.4.1.30 *Colour_RGBWAF_GREEN*

The current green value of DALI Type 8 (DT8) lamps, whose colour control is RGBWAF.

The valid values are from 0 to 254 and a value of NaN represents the DALI “MASK” value.

5.4.1.31 *Colour_RGBWAF_BLUE*

The current blue value of DALI Type 8 (DT8) lamps, whose colour control is RGBWAF.

The valid values are from 0 to 254 and a value of NaN represents the DALI “MASK” value.

5.4.1.32 *Colour_RGBWAF_WHITE*

The current white value of DALI Type 8 (DT8) lamps, whose colour control is RGBWAF.

The valid values are from 0 to 254 and a value of NaN represents the DALI “MASK” value.

5.4.1.33 *Colour_RGBWAF_AMBER*

The current amber value of DALI Type 8 (DT8) lamps, whose colour control is RGBWAF.

The valid values are from 0 to 254 and a value of NaN represents the DALI “MASK” value.

5.4.1.34 *Colour_RGBWAF_FREECOLOUR*

The current freecolour of DALI type 8 (DT8) lamps, whose colour control is RGBWAF.

The valid values are from 0 to 254 and a value of NaN represents the DALI “MASK” value.

5.5 Multi-State Output Object - Command Control of Lamp, Group and Channel

To control DALI scenes and other commands for the lamps, groups and channels, use Multi-State Output objects. Among other things recall, store and delete scenes with these objects.

5.5.1 Lamp, Group and Channel

List of available properties for these objects.

Property Identifier	Property ID	Property Datatype	Conformance Code
Object_Identifier	75	BACnetObjectIdentifier	R
Object_Name	77	CharacterString	R
Object_Type	79	BACnetObjectType	R
Present_Value	85	Unsigned	W
Status_Flags	111	BACnetStatusFlags	R
Event_State	36	BACnetEventState	R
Reliability	103	BACnetReliability	R
Out_Of_Service	81	BOOLEAN	W
Number_Of_States	74	Unsigned	R
State_Text	110	BACnetARRAY[N]of CharacterString	R
Priority_Array	87	BACnetPriorityArray	R
Relinquish_Default	104	REAL	R

5.5.1.1 Object_Identifier

The object instance number is the same as the associated Analog Output object and is also represented as TCLK.

- “T” is the type of object as follows, 0 for DALI lamps, 1 for DALI groups and 2 for DALI channels.
- “C” represents the DALI channel number, 0, 1, 2, or 3.
- “LL” represents for group objects, numbers 0-15 and for channel objects, number 00.

5.5.1.2 Object_Name

The **Object_Name** of the associated Analog Output object of the Group or Channel ending with “Scene”.

5.5.1.3 Object_Type

MULTISTATE_OUTPUT (14).

5.5.1.4 Present_Value

Among other things the Present_Value allows recalling, storing, and deleting the scenes. The available values are described below.

5.5.1.4.1 GO TO SCENE (1-16)

Allow sending the DALI command “**GO TO SCENE**” to the associated lamp, group or channel (broadcast).

5.5.1.4.2 STORE SCENE (17-32)

Allow sending the DALI command “**STORE DTR AS SCENE**” to the associated lamp, group or channel (broadcast).

5.5.1.4.3 REMOVE SCENE (33-48)

Allow sending the DALI command “**REMOVE FROM SCENE**” to the associated lamp, group or channel (broadcast).

5.5.1.4.4 NO COMMAND (50)

No command is executed.

5.5.1.4.5 RESET RUN HOURS (53)

Reset the run hours to zero.

5.5.1.4.6 EMERGENCY FUNCTION TEST START (55)

Start the function test for the lamps of the type “Self-contained emergency lighting (device type 1)”.

5.5.1.4.7 EMERGENCY DURATION TEST START (56)

Start the duration test for the lamps of the type “Self-contained emergency lighting (device type 1)”.

5.5.1.4.8 EMERGENCY TESTS STOP (57)

Stop the current test for the lamps of the type “Self-contained emergency lighting (device type 1)”.

5.5.1.4.9 DIM UP (58)

Allow sending the DALI command “**UP**” to the associated lamp, group or channel (broadcast).

5.5.1.4.10 DIM ON AND UP (59)

Allow sending the DALI command “**ON AND STEP UP**” to the associated lamp, group or channel (broadcast).

5.5.1.4.11 DIM DOWN (60)

Allow sending the DALI command “**DOWN**” to the associated lamp, group or channel (broadcast).

5.5.1.4.12 DIM DOWN AND OFF (61)

Allow sending the DALI command “**STEP DOWN AND OFF**” to the associated lamp, group or channel (broadcast).

5.5.1.4.13 OFF (65)

Allow sending the DALI command “**OFF**” to the associated lamp, group or channel (broadcast).

5.5.1.4.14 DIM STEP UP (66)

Allow sending the DALI command “**STEP UP**” to the associated lamp, group or channel (broadcast).

5.5.1.4.15 DIM STEP DOWN (67)

Allow sending the DALI command “**STEP DOWN**” to the associated lamp, group or channel (broadcast).

5.5.1.4.16 RECALL MIN LEVEL (68)

Allow sending the DALI command “**RECALL MIN LEVEL**” to the associated lamp, group or channel (broadcast).

5.5.1.4.17 RECALL MAX LEVEL (69)

Allow sending the DALI command “**RECALL MAX LEVEL**” to the associated lamp, group or channel (broadcast).

5.5.1.4.18 RECALL LAST LEVEL (70)

Recall Last Level.

5.5.1.4.19 EMERGENCY REST (71)

For the “Self-contained emergency lighting (device type 1)” only, starts the rest mode.

In this mode the lamp is intentionally off when it is powered from the battery.

Refer to the specification IEC 62386-202 for the complete details on the rest mode.

5.5.1.4.20 EMERGENCY INHIBIT (72)

For the “Self-contained emergency lighting (device type 1)” only, starts the inhibit mode.

In this mode the lamp is powered from the mains power supply but it is also prevented for 15 minutes from going into the emergency mode when an event of mains power failure occurs.

Refer to the specification IEC 62386-202 for the complete details on the inhibit mode.

5.5.1.4.21 EMERGENCY RESET INHIBIT (73)

For the “Self-contained emergency lighting (device type 1)” only, cancels the inhibit timer.

Refer to the specification IEC 62386-202 for the complete details on the inhibit mode.

5.5.1.4.22 EMERGENCY RESET FUNCTION TEST DONE FLAG (74)

For the “Self-contained emergency lighting (device type 1)” only, resets the function test done flag.

Refer to the specification IEC 62386-202 for the complete details on this command.

5.5.1.4.23 EMERGENCY RESET DURATION TEST DONE FLAG (75)

For the “Self-contained emergency lighting (device type 1)” only, resets the duration test done flag.

Refer to the specification IEC 62386-202 for the complete details on this command.

5.5.1.4.24 EMERGENCY START IDENTIFICATION (76)

For the “Self-contained emergency lighting (device type 1)” only, starts the identification.

Refer to the specification IEC 62386-202 for the complete details on this command.

5.5.1.4.25 GROUP ADD (77-92)

Allow sending the DALI command “**ADD TO GROUP**” to the associated lamp, group or channel (broadcast).

5.5.1.4.26 GROUP REMOVE (93-108)

Allow sending the DALI command “**REMOVE FROM GROUP**” to the associated lamp, group or channel (broadcast).

5.5.1.5 *Status_Flags*

This property indicates the general “reliability” of the object.

5.5.1.6 *Reliability*

This property indicates whether the operation of the Present_Value or the operation of the object is reliable. The values are as follows:

- NO_FAULT_DETECTED (0) - No fault has been detected.

5.5.1.7 *Out_Of_Service*

It is an indication of whether or not the object is in service.

5.6 Analog Input Object - Light Sensor

To obtain the light sensors’ illuminance level, use the Analog Input objects.

5.6.1 Light Sensor

List of available properties for these objects.

Property Identifier	Property ID	Property Datatype	Conformance Code
Object_Identifier	75	BACnetObjectIdentifier	R
Object_Name	77	CharacterString	W
Object_Type	79	BACnetObjectType	R
Present_Value	85	REAL	W
Description	28	CharacterString	R
Device_Type	31	CharacterString	R
Status_Flags	111	BACnetStatusFlags	R
Event_State	36	BACnetEventState	R
Reliability	103	BACnetReliability	R
Out_Of_Service	81	BOOLEAN	W
Units	117	BACnetEngineeringUnits	R
Min_Pres_Value	69	REAL	R
Max_Pres_Value	65	REAL	W
COV_Increment	22	REAL	W
Light_Hystereris	564	Unsigned	W
Light_Hystereris_Minimum	565	Unsigned	W
Light_Raw_Value	570	REAL	R
Light_Calibration_Measured_Value	571	REAL	R
Light_Calibration_Sensor_Value	572	REAL	R
Device_Serial_Number	573	OCTET STRING	R

5.6.1.1 *Object_Identifier*

The object instance number is represented as T CLL.

- “T” is the type of object as follows, 5 for DALI sensors.
- “C” represents the DALI channel number, 0, 1, 2, or 3.
- “LL” represents for sensor objects, numbers 00-31.

5.6.1.2 *Object_Name*

The name of the light sensor.

5.6.1.3 *Object_Type*

ANALOG_INPUT (0).

5.6.1.4 *Present_Value*

The current illuminance level.

5.6.1.5 *Description*

A description of the light sensor.

5.6.1.6 *Device_Type*

A text description of the physical DALI device connected to the analog input. For light sensor objects, it is “**DALI sensor**”.

5.6.1.7 *Status_Flags*

This property indicates the general “reliability” of an analog input object.

5.6.1.8 *Reliability*

This property indicates whether the operation of the DALI sensor is reliable. The values are as follows:

- NO_FAULT_DETECTED (0) - No fault has been detected.
- NO_SENSOR (1) - No physical device is connected to the input object.
- COMMUNICATION_FAILURE (12) - DALI device is offline.
- UNRELIABLE_OTHER (7) - A DALI error has been reported by the DALI sensor.

5.6.1.9 *Out_Of_Service*

It indicates whether the physical device that the object represents is in service.

5.6.1.10 *Units*

The unit for the Present_Value is luxes.

5.6.1.11 *Min_Pres_Value*

The minimum value is always zero (0). It represents the lowest value for the property Present_Value.

5.6.1.12 *Max_Pres_Value*

The maximum value is always infinity. It represents the highest value for the property Present_Value.

5.6.1.13 *COV_Increment*

This property specifies the minimum change of the Present_Value that issues a COVNotification.

5.6.1.14 *Light_Hystereris*

This is a percentage of the current sensor internal illuminance level.

The valid values are from 0 to 25 percent.

5.6.1.15 *Light_Hystereris_Minimum*

The minimum hysteresis.

The valid values are from 0 to 255.

5.6.1.16 *Light_Raw_Value*

The uncalibrated light sensor reading before applying any calibration calculations.

5.6.1.17 *Light_Calibration_Measured_Value*

The value measured by an external lux meter, used for calibrating the light sensor.

5.6.1.18 *Light_Calibration_Sensor_Value*

The light sensor reading value used as a reference point during the calibration process.

5.6.1.19 *Device_Serial_Number*

The DALI serial number of the input device.

5.7 Binary Input Object - Occupancy Sensors

To obtain the occupancy state, use the Binary Input objects.

5.7.1 Occupancy Sensor

List of available properties for these objects.

Property Identifier	Property ID	Property Datatype	Conformance Code
Object_Identifier	75	BACnetObjectIdentifier	R
Object_Name	77	CharacterString	W
Object_Type	79	BACnetObjectType	R
Present_Value	85	Enumerated	W
Description	28	CharacterString	R
Status_Flags	111	BACnetStatusFlags	R
Event_State	36	BACnetEventState	R
Reliability	103	BACnetReliability	R
Inactive_Text	46	CharacterString	R
Active_Text	4	CharacterString	R
Occupancy_Hold_Time	563	Unsigned	W
Allowed_Command	904	Enumerated	W
Buttons_States	905	Unsigned32	R
Buttons_Allowed_Command	927	Enumerated	W
Light_Hystereris	564	Unsigned	W
Light_Hystereris_Minimum	565	Unsigned	W
Light_Raw_Value	570	REAL	R
Light_Calibration_Measured_Value	571	REAL	R
Light_Calibration_Sensor_Value	572	REAL	R
Device_Serial_Number	573	OCTET STRING	R

5.7.1.1 *Object_Identifier*

The object instance number is represented as TCLK.

- “T” is the type of object as follows, 5 for DALI sensors.
- “C” represents the DALI channel number, 0, 1, 2, or 3.
- “LL” represents for sensor objects, numbers 00-31.

5.7.1.2 Object_Name

The name of the occupancy sensor.

5.7.1.3 Object_Type

BINARY_INPUT (3).

5.7.1.4 Present_Value

The current occupancy state.

5.7.1.5 Inactive_Text

“Unoccupied”.

5.7.1.6 Active_Text

“Occupied”.

5.7.1.7 Occupancy_Hold_Time

Hold time in seconds for the sensor.

Valid values are between 1 and 2 540 seconds (42.3 minutes) with an interval of 10 seconds.

5.7.1.8 Allowed_Command

Indicates whether the occupancy state of this object is used or not by the Room Light Control. At the startup, the value is *OFF_ON_ALLOWED*.

Name	Value	Description
OFF_ON_DISALLOWED	0	Both Unoccupied and Occupied states are unused.
OFF_ALLOWED	1	Only Unoccupied state is used.
ON_ALLOWED	2	Only Occupied state is used.
OFF_ON_ALLOWED	3	Both Unoccupied and Occupied states are used.

5.7.1.9 Buttons_States

Indicates the state of the buttons instances of the associated DALI input device. Each button instance state is represented by a bit in this 32-bit unsigned value.

For example, if only the instance 2 is pressed the value is 4.

For button instance configured as **Push-button**, the bit value toggle each time that the button is short pressed.

For button instance configured as **Switch**, the bit value is 1 when the button is pressed and 0 when the button is released.

5.7.1.10 Buttons_Allowed_Command

Indicates whether the button instances of the associated DALI input device can generate commands. At the startup, the value is *OFF_ON_ALLOWED*.

Name	Value	Description
OFF_ON_DISALLOWED	0	Both <i>Off</i> and <i>On</i> commands are disabled.
OFF_ALLOWED	1	Only <i>Off</i> commands are enabled.
ON_ALLOWED	2	Only <i>On</i> commands are used.
OFF_ON_ALLOWED	3	Both <i>Off</i> and <i>On</i> commands are enabled.

Off commands are the commands *Direct Value* with a value of 0, *Off* and *Off / Down*. As well as the toggle commands *On / Off* and *Last Level / Off* when the command to generate is *Off*.

On commands are the commands *Direct Value* with a value greater than 0, *Max Level*, *Max Level / Up*, *Min Level*, *Min Level / Down*, *Recall Scene*, *Recall Scene / Up* and *Recall Scene / Down*. As well as the toggle commands *On / Off* and *Last Level / Off* when the command to generate is not *Off*.

5.7.1.11 Light_Hystereris

The *Light_Hystereris* of the associated Analog Input object.

5.7.1.12 Light_Hystereris_Minimum

The *Light_Hystereris_Minimum* of the associated Analog Input object.

5.7.1.13 Light_Raw_Value

The *Light_Raw_Value* of the associated Analog Input object.

5.7.1.14 Light_Calibration_Measured_Value

The *Light_Calibration_Measured_Value* of the associated Analog Input object.

5.7.1.15 Light_Calibration_Sensor_Value

The *Light_Calibration_Sensor_Value* of the associated Analog Input object.

5.7.1.16 Device_Serial_Number

The DALI serial number of the input device.

5.8 Binary Input Object - Buttons

To obtain the button state of each individual button instance, use the Binary Input objects.

5.8.1 Button

List of available properties for these objects.

Property Identifier	Property ID	Property Datatype	Conformance Code
Object_Identifier	75	BACnetObjectIdentifier	R
Object_Name	77	CharacterString	W
Object_Type	79	BACnetObjectType	R
Present_Value	85	Enumerated	W
Description	28	CharacterString	R
Status_Flags	111	BACnetStatusFlags	R
Event_State	36	BACnetEventState	R
Reliability	103	BACnetReliability	R
Inactive_Text	46	CharacterString	R
Active_Text	4	CharacterString	R
Buttons_Allowed_Command	927	Enumerated	W
Device_Serial_Number	573	OCTET STRING	R

5.8.1.1 *Object_Identifier*

The object instance number is represented as 3CLLII.

- “3” the prefix is the number 3.
- “C” represents the DALI channel number, 0, 1, 2, or 3.
- “LL” represents the DALI input device, numbers 00-31.
- “II” represents the button instance number, numbers 00-31.

5.8.1.2 *Object_Name*

The name of the button.

5.8.1.3 *Object_Type*

BINARY_INPUT (3).

5.8.1.4 *Present_Value*

The current button state.

For button instance configured as **Push-button**, the value toggle each time that the button is short pressed.

For button instance configured as **Switch**, the value is ACTIVE when the button is pressed and INACTIVE when the button is released.

5.8.1.5 *Inactive_Text*

“Inactive”.

5.8.1.6 *Active_Text*

“Active”.

5.8.1.7 *Buttons_Allowed_Command*

Indicates whether the button instances of the associated DALI input device can generate commands. At the startup, the value is *OFF_ON_ALLOWED*.

Name	Value	Description
OFF_ON_DISALLOWED	0	Both <i>Off</i> and <i>On</i> commands are disabled.
OFF_ALLOWED	1	Only <i>Off</i> commands are enabled.
ON_ALLOWED	2	Only <i>On</i> commands are used.
OFF_ON_ALLOWED	3	Both <i>Off</i> and <i>On</i> commands are enabled.

Off commands are the commands *Direct Value* with a value of 0, *Off* and *Off / Down*. As well as the toggle commands *On / Off* and *Last Level / Off* when the command to generate is *Off*.

On commands are the commands *Direct Value* with a value greater than 0, *Max Level*, *Max Level / Up*, *Min Level*, *Min Level / Down*, *Recall Scene*, *Recall Scene / Up* and *Recall Scene / Down*. As well as the toggle commands *On / Off* and *Last Level / Off* when the command to generate is not *Off*.

5.8.1.8 *Device_Serial_Number*

The DALI serial number of the input device.

5.9 Multi-State Input Object - Scene Feedback of Group and Channel

To obtain the latest DALI scenes for the groups and channels, use Multi-State Input objects.

5.9.1 Group and Channel

List of available properties for these objects.

Property Identifier	Property ID	Property Datatype	Conformance Code
Object_Identifier	75	BACnetObjectIdentifier	R
Object_Name	77	CharacterString	R
Object_Type	79	BACnetObjectType	R
Present_Value	85	Unsigned	W
Description	28	CharacterString	R
Status_Flags	111	BACnetStatusFlags	R
Event_State	36	BACnetEventState	R
Out_Of_Service	81	BOOLEAN	W
Number_Of_States	74	Unsigned	R
State_Text	110	BACnetARRAY[N]of CharacterString	R

5.9.1.1 Object_Identifier

The object instance number is the same as the associated Analog Output object and is also represented as T CLL.

- “T” is the type of object as follows, 1 for DALI groups and 2 for DALI channels.
- “C” represents the DALI channel number, 0, 1, 2, or 3.
- “LL” represents for group objects, numbers 0-15 and for channel objects, number 00.

5.9.1.2 Object_Name

The **Object_Name** of the associated Analog Output object of the Group or Channel ending with “Scene Feedback”.

5.9.1.3 Object_Type

MULTISTATE_INPUT (13).

5.9.1.4 Present_Value

The Present_Value represents the latest scene recalling. The available values are described below.

NO COMMAND: - Values 1 for the initial value.

GO TO SCENE: - Values 2 to 17 for the DALI command “GO TO SCENE” to the associated group or channel (broadcast).

5.9.1.5 Description

The **Description** of the associated Analog Output object of the Group or Channel ending with “Scene Feedback”.

5.9.1.6 Status_Flags

This property indicates the general “reliability” of the object.

5.9.1.7 *Out_Of_Service*

It is an indication of whether or not the object is in service.

5.10 Loop Object - Room Light Control

To control the Room Light Control, use Loop objects. Visualise the states and configure the parameters with these objects.

5.10.1 Room Light Control

List of available properties for these objects.

Property Identifier	Property ID	Property Datatype	Conformance Code
Object_Identifier	75	BACnetObjectIdentifier	R
Object_Name	77	CharacterString	W
Object_Type	79	BACnetObjectType	R
Present_Value	85	REAL	R
Description	28	CharacterString	R
Status_Flags	111	BACnetStatusFlags	R
Event_State	36	BACnetEventState	R
Reliability	103	BACnetReliability	R
Out_Of_Service	81	BOOLEAN	W
Output_Units	117	BACnetEngineeringUnits	R
Manipulated_Variable_Reference	60	BACnetObjectPropertyReference	R
Controlled_Variable_Reference	19	BACnetObjectPropertyReference	R
Controlled_Variable_Value	21	REAL	R
Controlled_Variable_Units	20	BACnetEngineeringUnits	R
Setpoint_Reference	109	BACnetSetpointReference	R
Setpoint	108	REAL	R
Action	2	BACnetAction	R
Priority_For_Writing	88	Unsigned(1..16)	W
Occupancy_Variable_Reference	537	BACnetObjectPropertyReference	R
Occupancy_Variable_Value	538	BOOLEAN	R
Mode	539	Unsigned	W
Hold_Time	540	Unsigned	W
Ignore_Time	541	Unsigned	W
Occupied_Level	542	REAL	W
Unoccupied_Level	543	REAL	W
Step_Value	544	REAL	W
Lamp_2_Offset	550	REAL	W
Lamp_2_Limit	551	REAL	W
Override	560	REAL	R
Auto_Mode	561	BACnetBinaryPV	R

Occupancy_State	562	BACnetBinaryPV	R
Command	900	Unsigned	W
Setpoint_Occupied	901	REAL	W
Setpoint_Unoccupied	902	REAL	W
Deadband_Setpoint	903	REAL	W
Warning_Time	907	Unsigned	W
Warning_Command_Command	908	Unsigned	W
Warning_Command_Value	909	Unsigned	W
Occupied_Command_Command	910	Unsigned	W
Occupied_Command_Value	911	Unsigned	W
Unoccupied_Command_Command	912	Unsigned	W
Unoccupied_Command_Value	913	Unsigned	W
Minimum_Intensity	914	REAL	W
Maximum_Intensity	915	REAL	W
Daylight_Harvesting_Active	916	Unsigned	R
Occupied_Mode	917	Unsigned	W
Override_Timeout	918	Unsigned	W
Demand_Response_Value	919	REAL	W
Demand_Response_State	920	Unsigned	R
Occupied_Mode_Command_Enabl e	921	Unsigned	W

5.10.1.1 Object_Identifier

The object instance number is represented as CRR.

- “C” represents the DALI channel number, 0, 1, 2, or 3.
- “RR” represents the Room Light Control, numbers 00-15.

5.10.1.2 Object_Name

The name of the Room Light Control.

5.10.1.3 Object_Type

LOOP (12).

5.10.1.4 Present_Value

The light intensity in percentages for the Room Light Control.

5.10.1.5 Description

A description of the Room Light Control.

5.10.1.6 *Status_Flags*

This property indicates the general “reliability” of a loop object.

5.10.1.7 *Reliability*

This property indicates whether the operation of the Room Light Control is reliable. The values are as follows:

- NO_FAULT_DETECTED (0) - No fault has been detected.
- OPEN_LOOP (4) - The value of the light sensor does not changes when the Room Light Control output changes.
- COMMUNICATION_FAILURE (12) - The sensors or output devices are offline.
- UNRELIABLE_OTHER (7) - Another error has been reported.

5.10.1.8 *Out_Of_Service*

It indicates whether the algorithm that the object represents is in service.

5.10.1.9 *Output_Units*

The unit for the Present_Value is percent.

5.10.1.10 *Manipulated_Variable_Reference*

The output (Present_Value) of the control loop is written to the object and property designated by this property.

5.10.1.11 *Controlled_Variable_Reference*

It indicates the object and property of the light sensor.

5.10.1.12 *Controlled_Variable_Value*

The current value of the light sensor.

5.10.1.13 *Setpoint_Reference*

It indicates the object and property of the setpoint. It is always empty, indicating that the setpoint is contained in the Setpoint property.

5.10.1.14 *Setpoint*

The value of the current setpoint in lux.

5.10.1.15 *Action*

The action is DIRECT (0).

5.10.1.16 *Priority_For_Writing*

This property provides a priority to be used to write to the Manipulated_Variable_Reference that is controlled by this loop.

Valid values are between 1 and 16.

5.10.1.17 *Occupancy_Variable_Reference*

It indicates the object and property of the occupancy sensor.

5.10.1.18 *Occupancy_Variable_Value*

The current value of the occupancy sensor.

5.10.1.19 *Mode*

The current mode of the Room Light Control.

Name	Value	Description
Disabled	0	The Room Light Control is disabled
Enabled	1	The Room Light Control is enabled

5.10.1.20 *Hold_Time*

The hold time in seconds used for the occupancy state. The occupancy state remains in the occupied state for the hold time when the value of *Occupancy_Variable_Value* changes to be unoccupied.

Valid values are between 0 and 2 400 seconds (40 minutes) with an interval of 10 seconds.

5.10.1.21 *Ignore_Time*

The ignore time in seconds used for the occupancy state. Once the occupancy state changes to unoccupied the ignore time is used to temporarily ignore the occupied change of the *Occupancy_Variable_Value*.

Valid values are between 0 and 2 400 seconds (40 minutes) with an interval of 10 seconds.

5.10.1.22 *Occupied_Level*

The output light intensity when entering the occupied state.

5.10.1.23 *Unoccupied_Level*

The output light intensity when entering the unoccupied state.

5.10.1.24 *Step_Value*

The maximum value in percent that the Room Light Control can change its output per second, during constant light control.

Valid values are between 0 and 100 % with an interval of 0.5 %.

5.10.1.25 *Lamp_2_Offset*

The offset between the primary and the secondary output.

Valid values are between 0 and 100 % with an interval of 0.5 %.

5.10.1.26 *Lamp_2_Limit*

The value where the secondary output becomes the same as the primary output.

Valid values are between 0 and 100 % with an interval of 0.5 %.

5.10.1.27 *Override*

The value of the output override in percent (0 - 100%). When the value is NaN the override is disabled.

5.10.1.28 *Auto_Mode*

Inactive (0): The Room Light Control is currently overridden or is disabled.

Active (1): The Room Light Control is not currently overridden and is active.

5.10.1.29 *Occupancy_State*

Indicates the current occupancy state of the Room Light Control.

Inactive (0): The occupancy state is unoccupied.

Active (1): The occupancy state is occupied.

5.10.1.30 *Command*

Allows to execute commands on the Room Light Control.

5.10.1.30.1 *NO COMMAND (1)*

No command is executed.

5.10.1.30.2 *START DEMAND RESPONSE (2)*

Starts the demand response.

5.10.1.30.3 *STOP DEMAND RESPONSE (3)*

Stops the demand response.

5.10.1.30.4 *START DAYLIGHT HARVESTING (4)*

Starts the daylight harvesting.

5.10.1.30.5 *STOP DAYLIGHT HARVESTING (5)*

Stops the daylight harvesting.

5.10.1.30.6 *START OVERRIDE (6)*

Starts the override.

5.10.1.30.7 *STOP OVERRIDE (7)*

Stops the override.

5.10.1.30.8 *ENABLE (8)*

Enable the Room Light Control.

5.10.1.30.9 *DISABLE (9)*

Disable the Room Light Control.

5.10.1.30.10 *OCCUPIED NO COMMAND (10)*

Inhibits the occupied and unoccupied commands.

5.10.1.30.11 OCCUPIED UNOCCUPIED COMMAND (11)

Allows only the unoccupied commands.

5.10.1.30.12 OCCUPIED OCCUPIED COMMAND (12)

Allows only the occupied commands.

5.10.1.30.13 OCCUPIED ALL COMMAND (13)

Allows the occupied and unoccupied commands.

5.10.1.30.14 OCCUPIED MODE UNOCCUPIED (14)

Sets the occupied mode to unoccupied.

5.10.1.30.15 OCCUPIED MODE OCCUPIED (15)

Sets the occupied mode to occupied.

5.10.1.31 Setpoint_Occupied

The setpoint of desired light illuminance of the room when the occupancy state is occupied.

Valid values are between 0 and 65 534 lux with an interval of 1 lux.

5.10.1.32 Setpoint_Unoccupied

The setpoint of desired light illuminance of the room when the occupancy state is unoccupied. It is also possible to use a relative setpoint to the Setpoint_Occupied, for this a negative is used that will represent a percentage to reduce from the Setpoint_Occupied.

Valid values are between 0 and 65 534 lux with an interval of 1 lux. When relative setpoint is used the valid values are between -100 and 0 % with an interval of 1 %.

5.10.1.33 Deadband_Setpoint

The dead band in lux used by the current setpoint.

Valid values are between 0 and 65 534 lux with an interval of 1 lux.

5.10.1.34 Warning_Time

The warning time in seconds used for the occupancy state. The Warning_Command is executed before the Unoccupied_Command which is executed after the Warning_Time, when the value of Occupancy_Variable_Value changes to be unoccupied.

Valid values are between 0 and 2 400 seconds (40 minutes) with an interval of 10 seconds.

5.10.1.35 Warning_Command_Command, Occupied_Command_Command and Unoccupied_Command_Command

Name	Value	Description
Disabled	0	The command is disabled.
Direct Value	1	Direct light value.
Max Level	2	Recall Max Level.
Off	3	Off.
Min Level	4	Recall Min Level.
Recall Scene	5	Recall Scene.
Start Daylight Harvesting	6	Start the Room Light Control daylight harvesting.
Stop Daylight Harvesting	7	Stop the Room Light Control daylight harvesting.
Relinquish	8	Relinquish the priority.

5.10.1.36 Warning_Command_Value, Occupied_Command_Value and Unoccupied_Command_Value

Name	Value Range	Unit
Disabled	0	
Direct Value	0 - 100	Percent
Max Level		
Off		
Min Level		
Recall Scene	0 - 15	Scene number
Start Daylight Harvesting		
Stop Daylight Harvesting		
Relinquish		

5.10.1.37 Minimum_Intensity

Minimum intensity of the Room Light Control output.

Valid values are between 0 and 100 % with an interval of 0.5 %.

5.10.1.38 Maximum_Intensity

Maximum intensity of the Room Light Control output.

Valid values are between 0 and 100 % with an interval of 0.5 %.

5.10.1.39 Daylight_Harvesting_Active

This property indicates whether the daylight harvesting control is currently active or not.

Name	Value	Description
Inactive	0	The daylight harvesting control is currently inactive.
Active	1	The daylight harvesting control is currently active.

5.10.1.40 Occupied_Mode

The current occupancy mode.

Unoccupied (0): The Room Light Control is unoccupied.

Occupied (1): The Room Light Control is occupied.

5.10.1.41 Override_Timeout

The override timeout in seconds. The override remains active for this period.

Valid values are between 0 and 72 000 seconds (20 hours) with an interval of 300 seconds. When the value is zero, this functionality is disabled.

Override is automatically initiated when the output of a Room Light Control is modified from another source than the Room Light Control itself.

For example, this allows a DALI button or a BACnet group command to temporarily override the output.

While the override timeout is active, Daylight Harvesting is suspended. When the override timeout ends, daylight harvesting is un-suspended and if it is in unoccupied state, the Warning and the Unoccupied commands are executed.

5.10.1.42 Demand_Response_Value

The demand response allows limiting the illuminance of the room. A negative value reduces the illuminance of the room by this value in percentages. A positive value increases the illuminance of the room by this value in percentages. When daylight harvesting is active, the setpoint is decreased or increased by this value in percentages.

Valid values are between -100 and 100 percent with an interval of 1 percent.

5.10.1.43 Demand_Response_State

The current state of the demand response.

Inactive (0): The demand response is inactive.

Active (1): The demand response is active.

5.10.1.44 Occupied_Mode_Command_Enable

It allows enabling and disabling the execution of the occupancy command when Occupied_Mode is modified.

Name	Value	Description
NO_COMMAND	0	No command is executed.
UNOCCUPIED_COMMAND	1	Only unoccupied command is executed.
OCCUPIED_COMMAND	2	Only occupied command is executed.
ALL	3	Both Unoccupied and Occupied commands are executed.

5.11 Analog Value - Lamp, Group, and Channel

Some lamp, group and channel parameters are also available via these objects. Those values are also available via the proprietary properties of the associated Analog Output object.

5.11.1 Lamp, Group, Channel

List of available properties for these objects.

Property Identifier	Property ID	Property Datatype	Conformance Code
Object_Identifier	75	BACnetObjectIdentifier	R
Object_Name	77	CharacterString	W
Object_Type	79	BACnetObjectType	R
Present_Value	85	REAL	R
Description	28	CharacterString	R
Status_Flags	111	BACnetStatusFlags	R
Event_State	36	BACnetEventState	R
Reliability	103	BACnetReliability	R
Out_Of_Service	81	BOOLEAN	W
Units	117	BACnetEngineeringUnits	R
Min_Pres_Value	69	REAL	R
Max_Pres_Value	65	REAL	R
Resolution	106	REAL	R

5.11.1.1 Object_Identifier

The object instance number is represented as 1TCLLII.

- “1” the prefix is the number 1.
- “T” is the type of object as follows, 0 for DALI lamps, 1 for DALI groups and 2 for DALI channels.
- “C” represents the DALI channel number, 0, 1, 2, or 3.
- “LL” represents for lamp objects, numbers 00-63, for group objects, numbers 00-15 and for channel objects, number 00.
- “II” represents the parameter, numbers 00-99.

Number	Name
00	Colour_Temp
01	Colour_XYC_X
02	Colour_XYC_Y
03	Colour_TC_TC

5.11.1.2 *Object_Name*

The name of the parameter with the name of the Analog Output as a prefix.

5.11.1.3 *Object_Type*

ANALOG VALUE (2).

5.11.1.4 *Present_Value*

The value of the parameter.

5.11.1.4.1 *Colour_Temp*

The colour temperature in Kelvin (K).

Same value as the property Colour_Temp of the associated Analog Output object.

5.11.1.4.2 *Colour_XYC_X*

The x-coordinate for xy-Coordinate.

Same value as the property Colour_XYC_X of the associated Analog Output object.

5.11.1.4.3 *Colour_XYC_Y*

The y-coordinate for xy-Coordinate.

Same value as the property Colour_XYC_Y of the associated Analog Output object.

5.11.1.4.4 *Colour_TC_TC*

The colour temperature in 1 Mirek (K).

Same value as the property Colour_TC_TC of the associated Analog Output object.

5.11.1.5 *Description*

A description of the object.

5.11.1.6 *Status_Flags*

This property indicates the general “reliability” of the object.

5.11.1.7 *Reliability*

This property indicates whether the operation of the object is reliable. The values are as follows:

- NO_FAULT_DETECTED (0) - No fault has been detected.

5.11.1.8 Out_Of_Service

It indicates whether the algorithm that the object represents is in service.

5.11.1.9 Units, Min_Pres_Value, Max_Pres_Value, Resolution

The Units, Min_Pres_Value, Max_Pres_Value and Resolution for the Present_Value.

Name	Units	Min_Pres_Value	Max_Pres_Value	Resolution
Colour_Temp	degrees-kelvin	15.26	1000000	REAL EPSILON
Colour_XYC_X	no-units	0	65534	1
Colour_XYC_Y	no-units	0	65534	1
Colour_TC_TC	no-units	1	65534	1

5.12 Analog Value - Input Device

Some DALI input device parameters are also available via these objects. Those values are also available via the proprietary properties of the associated Binary Input object.

5.12.1 Input Device

List of available properties for these objects.

Property Identifier	Property ID	Property Datatype	Conformance Code
Object_Identifier	75	BACnetObjectIdentifier	R
Object_Name	77	CharacterString	W
Object_Type	79	BACnetObjectType	R
Present_Value	85	REAL	R
Description	28	CharacterString	R
Status_Flags	111	BACnetStatusFlags	R
Event_State	36	BACnetEventState	R
Reliability	103	BACnetReliability	R
Out_Of_Service	81	BOOLEAN	W
Units	117	BACnetEngineeringUnits	R
Min_Pres_Value	69	REAL	R
Max_Pres_Value	65	REAL	R
Resolution	106	REAL	R

5.12.1.1 Object_Identifier

The object instance number is represented as 5CLLII.

- “5” the prefix is the number 5.
- “C” represents the DALI channel number, 0, 1, 2, or 3.

- “LL” represents the DALI input device, numbers 00-31.
- “II” represents the parameter, numbers 00-99.

Number	Name
00	Allowed_Command
01	Buttons_Allowed_Command
02	Occupancy_Hold_Time
03	Light_Hystereris
04	Light_Hystereris_Minimum
05	Light_Raw_Value
06	Light_Calibration_Measured_Value
07	Light_Calibration_Sensor_Value

5.12.1.2 Object_Name

The name of the parameter with the name of the Binary Input as a prefix.

5.12.1.3 Object_Type

ANALOG VALUE (2).

5.12.1.4 Present_Value

The value of the parameter.

5.12.1.4.1 Allowed_Command

Same value as the property Allowed_Command of the associated Binary Input object.

5.12.1.4.2 Buttons_Allowed_Command

Same value as the property Buttons_Allowed_Command of the associated Binary Input object.

5.12.1.4.3 Occupancy_Hold_Time

Same value as the property Occupancy_Hold_Time of the associated Binary Input object.

5.12.1.4.4 Light_Hystereris

Same value as the property Light_Hystereris of the associated Binary Input object.

5.12.1.4.5 Light_Hystereris_Minimum

Same value as the property Light_Hystereris_Minimum of the associated Binary Input object.

5.12.1.4.6 Light_Raw_Value

Same value as the property Light_Raw_Value of the associated Binary Input object.

5.12.1.4.7 Light_Calibration_Measured_Value

Same value as the property Light_Calibration_Measured_Value of the associated Binary Input object.

5.12.1.4.8 Light_Calibration_Sensor_Value

Same value as the property Light_Calibration_Sensor_Value of the associated Binary Input object.

5.12.1.5 Description

A description of the object.

5.12.1.6 Status_Flags

This property indicates the general “reliability” of the object.

5.12.1.7 Reliability

This property indicates whether the operation of the object is reliable. The values are as follows:

- NO_FAULT_DETECTED (0) - No fault has been detected.

5.12.1.8 Out_Of_Service

It indicates whether the algorithm that the object represents is in service.

5.12.1.9 Units, Min_Pres_Value, Max_Pres_Value, Resolution

The Units, Min_Pres_Value, Max_Pres_Value and Resolution for the Present_Value.

Name	Units	Min_Pres_Value	Max_Pres_Value	Resolution
Allowed_Command	no-units	0	3	1
Buttons_Allowed_Command	no-units	0	3	1
Occupancy_Hold_Time	seconds	1	2540	1
Light_Hystereris	percent	0	25	1
Light_Hystereris_Minimum	no-units	0	255	1
Light_Raw_Value	no-units	0		1
Light_Calibration_Measured_Value	luxes	0		1
Light_Calibration_Sensor_Value	no-units	0		1

5.13 Analog Value - Room Light Control

Some Room Light Control parameters are also available via these objects. Those values are also available via the proprietary properties of the associated Loop object.

5.13.1 Room Light Control

List of available properties for these objects.

Property Identifier	Property ID	Property Datatype	Conformance Code
Object_Identifier	75	BACnetObjectIdentifier	R
Object_Name	77	CharacterString	W
Object_Type	79	BACnetObjectType	R
Present_Value	85	REAL	R
Description	28	CharacterString	R
Status_Flags	111	BACnetStatusFlags	R
Event_State	36	BACnetEventState	R
Reliability	103	BACnetReliability	R
Out_Of_Service	81	BOOLEAN	W
Units	117	BACnetEngineeringUnits	R
Min_Pres_Value	69	REAL	R
Max_Pres_Value	65	REAL	R
Resolution	106	REAL	R

5.13.1.1 Object_Identifier

The object instance number is represented as 9CRR11.

- “9” the prefix is the number 9.
- “C” represents the DALI channel number, 0, 1, 2, or 3.
- “RR” represents the Room Light Control, numbers 00-15.
- “11” represents the parameter, numbers 00-99.

Number	Name
00	Value
01	Controlled_Variable_Value
02	Setpoint
03	Hold_Time
04	Ignore_Time
05	Occupied_Level
06	Unoccupied_Level
07	Step_Value
08	Lamp_2_Offset
09	Lamp_2_Limit
10	Override
11	Setpoint_Occupied
12	Setpoint_Unoccupied
13	Deadband_Setpoint
14	Warning_Time
15	Warning_Command_Value
16	Occupied_Command_Value
17	Unoccupied_Command_Value
18	Minimum_Intensity
19	Maximum_Intensity
20	Override_Timeout
21	Demand_Response_Value

5.13.1.2 *Object_Name*

The name of the parameter with the name of the Room Light Control as a prefix.

5.13.1.3 *Object_Type*

ANALOG VALUE (2).

5.13.1.4 *Present_Value*

The value of the parameter.

5.13.1.4.1 *Value*

The light intensity in percentages for the Room Light Control.

Same value as the property Present_Value of the associated Loop object.

5.13.1.4.2 `Controlled_Variable_Value`

The current value of the light sensor.

Same value as the property `Controlled_Variable_Value` of the associated Loop object.

5.13.1.4.3 `Setpoint`

The value of the current setpoint in lux.

Same value as the property `Setpoint` of the associated Loop object.

5.13.1.4.4 `Hold_Time`

The hold time in seconds used for the occupancy state. The occupancy state remains in the occupied state for the hold time when the value of `Occupancy_Variable_Value` changes to be unoccupied.

Valid values are between 0 and 2 400 seconds (40 minutes) with an interval of 10 seconds.

Same value as the property `Hold_Time` of the associated Loop object.

5.13.1.4.5 `Ignore_Time`

The ignore time in seconds used for the occupancy state. Once the occupancy state changes to unoccupied the ignore time is used to temporarily ignore the occupied change of the `Occupancy_Variable_Value`.

Valid values are between 0 and 2 400 seconds (40 minutes) with an interval of 10 seconds.

Same value as the property `Ignore_Time` of the associated Loop object.

5.13.1.4.6 `Occupied_Level`

The output light intensity when entering the occupied state.

Same value as the property `Occupied_Level` of the associated Loop object.

5.13.1.4.7 `Unoccupied_Level`

The output light intensity when entering the unoccupied state.

Same value as the property `Unoccupied_Level` of the associated Loop object.

5.13.1.4.8 `Step_Value`

The maximum value in percent that the Room Light Control can change its output per second, during constant light control.

Valid values are between 0 and 100 % with an interval of 0.5 %.

Same value as the property `Step_Value` of the associated Loop object.

5.13.1.4.9 `Lamp_2_Offset`

The offset between the primary and the secondary output.

Valid values are between 0 and 100 % with an interval of 0.5 %.

Same value as the property Lamp_2_Offset of the associated Loop object.

5.13.1.4.10 Lamp_2_Limit

The value where the secondary output becomes the same as the primary output.

Valid values are between 0 and 100 % with an interval of 0.5 %.

Same value as the property Lamp_2_Limit of the associated Loop object.

5.13.1.4.11 Override

The value of the output override in percent (0 - 100%). When the value is NaN the override is disabled.

Same value as the property Override of the associated Loop object.

5.13.1.4.12 Setpoint_Occupied

The setpoint of desired light illuminance of the room when the occupancy state is occupied.

Valid values are between 0 and 65 534 lux with an interval of 1 lux.

Same value as the property Setpoint_Occupied of the associated Loop object.

5.13.1.4.13 Setpoint_Unoccupied

The setpoint of desired light illuminance of the room when the occupancy state is unoccupied. It is also possible to use a relative setpoint to the Setpoint_Occupied, for this a negative is used that will represent a percentage to reduce from the Setpoint_Occupied.

Valid values are between 0 and 65 534 lux with an interval of 1 lux. When relative setpoint is used the valid values are between -100 and 0 % with an interval of 1 %.

Same value as the property Setpoint_Unoccupied of the associated Loop object.

5.13.1.4.14 Deadband_Setpoint

The dead band in lux used by the current setpoint.

Valid values are between 0 and 65 534 lux with an interval of 1 lux.

Same value as the property Deadband_Setpoint of the associated Loop object.

5.13.1.4.15 Warning_Time

The warning time in seconds used for the occupancy state. The Warning_Command is executed before the Unoccupied_Command which is executed after the Warning_Time, when the value of Occupancy_Variable_Value changes to be unoccupied.

Valid values are between 0 and 2 400 seconds (40 minutes) with an interval of 10 seconds.

Same value as the property Warning_Time of the associated Loop object.

5.13.1.4.16 [Warning_Command_Value](#), [Occupied_Command_Value](#), [Unoccupied_Command_Value](#)

Name	Value Range	Unit
Disabled	0	
Direct Value	0 - 100	Percent
Max Level		
Off		
Min Level		
Recall Scene	0 - 15	Scene number
Start Daylight Harvesting		
Stop Daylight Harvesting		
Relinquish		

Same value as the property [Warning_Command_Value](#), [Occupied_Command_Value](#) or [Unoccupied_Command_Value](#) of the associated Loop object.

5.13.1.4.17 [Minimum_Intensity](#)

Minimum intensity of the Room Light Control output.

Valid values are between 0 and 100 % with an interval of 0.5 %.

Same value as the property [Minimum_Intensity](#) of the associated Loop object.

5.13.1.4.18 [Maximum_Intensity](#)

Maximum intensity of the Room Light Control output.

Valid values are between 0 and 100 % with an interval of 0.5 %.

Same value as the property [Maximum_Intensity](#) of the associated Loop object.

5.13.1.4.19 [Override_Timeout](#)

The override timeout in seconds used when unoccupied. The override remains active for this time, before returning to the unoccupied state.

Valid values are between 0 and 72 000 seconds (20 hours) with an interval of 300 seconds.

Same value as the property [Override_Timeout](#) of the associated Loop object.

5.13.1.4.20 [Demand_Response_Value](#)

The demand response allows limiting the illuminance of the room. A negative value reduces the illuminance of the room by this value in percentages. A positive value increases the illuminance of the room by this value in percentages. When daylight harvesting is active, the setpoint is decreased or increased by this value in percentages.

Valid values are between -100 and 100 percent with an interval of 1 percent.

Same value as the property Demand_Response_Value of the associated Loop object.

5.13.1.5 Description

A description of the object.

5.13.1.6 Status_Flags

This property indicates the general “reliability” of the object.

5.13.1.7 Reliability

This property indicates whether the operation of the object is reliable. The values are as follows:

- NO_FAULT_DETECTED (0) - No fault has been detected.

5.13.1.8 Out_Of_Service

It indicates whether the algorithm that the object represents is in service.

5.13.1.9 Units, Min_Pres_Value, Max_Pres_Value, Resolution

The Units, Min_Pres_Value, Max_Pres_Value and Resolution for the Present_Value.

Name	Units	Min_Pres_Value	Max_Pres_Value	Resolution
Value	no-units	0	REAL MAXIMUM	REAL EPSILON
Controlled_Variable_Value	no-units	0	REAL MAXIMUM	REAL EPSILON
Setpoint	no-units	0	REAL MAXIMUM	REAL EPSILON
Hold_Time	seconds	0	2400	10
Ignore_Time	seconds	0	2400	10
Occupied_Level	no-units	0	REAL MAXIMUM	REAL EPSILON
Unoccupied_Level	no-units	0	REAL MAXIMUM	REAL EPSILON
Step_Value	percent	0	100	0.5
Lamp_2_Offset	percent	0	100	0.5
Lamp_2_Limit	percent	0	100	0.5
Override	percent	0	1	REAL EPSILON
Setpoint_Occupied	luxes	0	65534	1
Setpoint_Unoccupied	no-units	-100	65534	1
Deadband_Setpoint	luxes	0	65534	1
Warning_Time	seconds	0	2400	10
Warning_Command_Value	no-units	0	255	1
Occupied_Command_Value	no-units	0	255	1
Unoccupied_Command_Value	no-units	0	255	1
Minimum_Intensity	percent	0	100	0.5
Maximum_Intensity	percent	0	100	0.5
Override_Timeout	seconds	0	72000	300
Demand_Response_Value	percent	-100	100	1

5.14 Multi-State Value Object - Value of Lamp, Group and Channel

Some Lamps, Groups and Channels parameters are also available via these objects. Those values are also available via the properties values of the associated Analog Output object.

As Multi-State Value Present_Value starts at one (1), see the Present Value section since the values of this object may be different from the associated property values of the Analog Output object.

5.14.1 Lamp, Group and Channel

List of available properties for these objects.

Property Identifier	Property ID	Property Datatype	Conformance Code
Object_Identifier	75	BACnetObjectIdentifier	R
Object_Name	77	CharacterString	R
Object_Type	79	BACnetObjectType	R
Present_Value	85	Unsigned	W
Status_Flags	111	BACnetStatusFlags	R
Event_State	36	BACnetEventState	R
Out_Of_Service	81	BOOLEAN	W
Number_Of_States	74	Unsigned	R
State_Text	110	BACnetARRAY[N]of CharacterString	R

5.14.1.1 Object_Identifier

The object instance number is represented as TCLLII.

- “T” is the type of object as follows, 0 for DALI lamps, 1 for DALI groups and 2 for DALI channels.
- “C” represents the DALI channel number, 0, 1, 2, or 3.
- “LL” represents for lamp objects, numbers 00-63, for group objects, numbers 00-15 and for channel objects, number 00.
- “II” represents the parameter, numbers 00-99.

Number	Name
00	Reliability

5.14.1.2 Object_Name

The name of the parameter with the name of the associated Analog Output object as a prefix.

5.14.1.3 Object_Type

MULTISTATE_VALUE (19).

5.14.1.4 Present_Value

The value of the parameter.

5.14.1.4.1 Reliability

The current reliability of the associated lamp, group or channel.

Represents the value of the property Reliability of the associated Analog Output object.

Name	Value	Description
NO_FAULT_DETECTED	1	No fault has been detected
NO_OUTPUT	7	No DALI device is connected to the output object
UNRELIABLE_OTHER	8	An error has been reported by the DALI lamp
COMMUNICATION_FAILURE	13	DALI device is offline

5.15 Multi-State Value Object - Room Light Control

Some Room Light Control parameters are also available via these objects. Those values are also available via the values of the associated Loop object.

As Multi-State Value Present_Value starts at one (1), see the Present Value section since the values of this object may be different from the associated property values of the Loop object.

5.15.1 Room Light Control

List of available properties for these objects.

Property Identifier	Property ID	Property Datatype	Conformance Code
Object_Identifier	75	BACnetObjectIdentifier	R
Object_Name	77	CharacterString	R
Object_Type	79	BACnetObjectType	R
Present_Value	85	Unsigned	W
Status_Flags	111	BACnetStatusFlags	R
Event_State	36	BACnetEventState	R
Out_Of_Service	81	BOOLEAN	W
Number_Of_States	74	Unsigned	R
State_Text	110	BACnetARRAY[N]of CharacterString	R

5.15.1.1 Object_Identifier

The object instance number is represented as 9CRR11.

- “9” the prefix is the number 9.
- “C” represents the DALI channel number, 0, 1, 2, or 3.
- “RR” represents the Room Light Control, numbers 00-15.
- “11” represents the parameter, numbers 00-99.

Number	Name
00	Mode
01	Auto_Mode
02	Occupancy_State
03	Command
04	Warning_Command_Command
05	Occupied_Command_Command
06	Unoccupied_Command_Command
07	Daylight_Harvesting_Active
08	Occupied_Mode
09	Demand_Response_State
10	Occupied_Mode_Command_Enable

5.15.1.2 Object_Name

The name of the parameter with the name of the Room Light Control as a prefix.

5.15.1.3 Object_Type

MULTISTATE_VALUE (19).

5.15.1.4 Present_Value

The value of the parameter.

5.15.1.4.1 Mode

The current mode of the Room Light Control.

Represents the value of the property Mode of the associated Loop object.

Name	Value	Description
Disabled	1	The Room Light Control is disabled
Enabled	2	The Room Light Control is enabled

5.15.1.5 Auto_Mode

Represents the value of the property Auto_Mode of the associated Loop object.

Inactive (1): The Room Light Control is currently overridden or is disabled.

Active (2): The Room Light Control is not currently overridden and is active.

5.15.1.6 Occupancy_State

Indicates the current occupancy state of the Room Light Control.

Represents the value of the property Occupancy_State of the associated Loop object.

Inactive (1): The occupancy state is unoccupied.

Active (2): The occupancy state is occupied.

5.15.1.7 Command

Allows to execute commands on the Room Light Control.

Represents the value of the property Command of the associated Loop object.

5.15.1.7.1 NO COMMAND (1)

No command is executed.

5.15.1.7.2 START DEMAND RESPONSE (2)

Starts the demand response.

5.15.1.7.3 STOP DEMAND RESPONSE (3)

Stops the demand response.

5.15.1.7.4 START DAYLIGHT HARVESTING (4)

Starts the daylight harvesting.

5.15.1.7.5 STOP DAYLIGHT HARVESTING (5)

Stops the daylight harvesting.

5.15.1.7.6 START OVERRIDE (6)

Starts the override.

5.15.1.7.7 STOP OVERRIDE (7)

Stops the override.

5.15.1.7.8 ENABLE (8)

Enables the Room Light Control.

5.15.1.7.9 DISABLE (9)

Disables the Room Light Control.

5.15.1.8 Warning_Command_Command, Occupied_Command_Command and Unoccupied_Command_Command

Represents the value of the properties Warning_Command_Command, Occupied_Command_Command and Unoccupied_Command_Command of the associated Loop object.

Name	Value	Description
Disabled	1	The command is disabled.
Direct Value	2	Direct light value.
Max Level	3	Recall Max Level.
Off	4	Off.
Min Level	5	Recall Min Level.
Recall Scene	6	Recall Scene.
Start Daylight Harvesting	7	Start the Room Light Control daylight harvesting.
Stop Daylight Harvesting	8	Stop the Room Light Control daylight harvesting.
Relinquish	9	Relinquish the priority.

5.15.1.9 Daylight_Harvesting_Active

This property indicates whether the daylight harvesting control is currently active or not.

Represents the value of the property Daylight_Harvesting_Active of the associated Loop object.

Name	Value	Description
Inactive	1	The daylight harvesting control is currently inactive.
Active	2	The daylight harvesting control is currently active.

5.15.1.10 Occupied_Mode

The current occupancy mode.

Represents the value of the property Occupied_Mode of the associated Loop object.

Unoccupied (1): The Room Light Control is unoccupied.

Occupied (2): The Room Light Control is occupied.

5.15.1.11 Demand_Response_State

The current state of the demand response.

Represents the value of the property Demand_Response_State of the associated Loop object.

Inactive (1): The demand response is inactive.

Active (2): The demand response is active.

5.15.1.12 Occupied_Mode_Command_Enable

It allows enabling and disabling the execution of the occupancy command when Occupied_Mode is modified.

Represents the value of the property Occupied_Mode_Command_Enable of the associated Loop object.

Name	Value	Description
NO_COMMAND	1	No command is executed.
UNOCCUPIED_COMMAND	2	Only unoccupied command is executed.
OCCUPIED_COMMAND	3	Only occupied command is executed.
ALL	4	Both Unoccupied and Occupied commands are executed.

5.15.1.13 Status_Flags

This property indicates the general “reliability” of the object.

5.15.1.14 Reliability

This property indicates whether the operation of the Present_Value or the operation of the object is reliable. The values are as follows:

- NO_FAULT_DETECTED (0) - No fault has been detected.

5.15.1.15 Out_Of_Service

It indicates whether the algorithm that the object represents is in service.

5.16 Multi-State Value Object - Commander

Some Commander parameters are also available via these objects.

5.16.1 Commander

List of available properties for these objects.

Property Identifier	Property ID	Property Datatype	Conformance Code
Object_Identifier	75	BACnetObjectIdentifier	R
Object_Name	77	CharacterString	R
Object_Type	79	BACnetObjectType	R
Present_Value	85	Unsigned	W
Status_Flags	111	BACnetStatusFlags	R
Event_State	36	BACnetEventState	R
Out_Of_Service	81	BOOLEAN	W
Number_Of_States	74	Unsigned	R
State_Text	110	BACnetARRAY[N]of CharacterString	R

5.16.1.1 Object_Identifier

The object instance number is represented as 7CCCI.

- “7” the prefix is the number 7.
- “C” represents the DALI channel number, 0, 1, 2, or 3.
- “CC” represents the Commander, numbers 00-15.

- “II” represents the parameter, numbers 00-99.

Number	Name
00	Command

5.16.1.2 *Object_Name*

The name of the parameter with the name of the Commander as a prefix.

5.16.1.3 *Object_Type*

MULTISTATE_VALUE (19).

5.16.1.4 *Present_Value*

The value of the parameter.

5.16.1.4.1 *Command*

Allows to execute commands on the Commander.

5.16.1.4.1.1 NO COMMAND (1)

No command is executed.

5.16.1.4.1.2 START (2)

Starts the Commander.

5.16.1.4.1.3 STOP (3)

Stops the Commander.

5.16.1.5 *Status_Flags*

This property indicates the general “reliability” of the object.

5.16.1.6 *Reliability*

This property indicates whether the operation of the Present_Value or the operation of the object is reliable. The values are as follows:

- NO_FAULT_DETECTED (0) - No fault has been detected.

5.16.1.7 *Out_Of_Service*

It indicates whether the algorithm that the object represents is in service.

6 Room Light Control

The Room Light Control (RLC) allow controlling the lighting of rooms according to their occupancy and illuminance.

6.1 Occupancy Sensors

One or multiple occupancy sensors allow reducing or completely turn off the lighting of a room in response to its occupancy state. The occupancy sensors determine the Occupied state of the room.

Related BACnet properties: *Occupancy_Variable_Value*.

6.2 Occupied Mode

The Occupied Mode is normally written twice each day to enable and disable the Override Timeout. When the Occupied Mode is Occupied the Override Timeout is disabled. When the Occupied Mode is Unoccupied the Override Timeout is enabled. It is possible for changes to the Occupied Mode to automatically execute or not the Occupied, Unoccupied and Warning commands.

Related BACnet properties: *Occupied_Mode*, *Occupied_Mode_Command_Enable*, *Override_Timeout*, *Occupied_Command_Command*, *Occupied_Command_Value*, *Unoccupied_Command_Command*, *Unoccupied_Command_Value*, *Warning_Command_Command*, *Warning_Command_Value*.

6.3 Occupied Command

When the room enters in Occupied state, the Occupied command is executed. When using a direct value as the command, the command is inhibited if the command value is lower than the current output value.

Related BACnet properties: *Occupied_Command_Command*, *Occupied_Command_Value*, *Occupancy_Variable_Value*.

6.4 Unoccupied Command

When the room enters in Unoccupied state, the Unoccupied command is executed. When using a direct value as the command, the command is inhibited if the command value is greater than the current output value.

Related BACnet properties: *Unoccupied_Command_Command*, *Unoccupied_Command_Value*, *Occupancy_Variable_Value*.

6.5 Unoccupied Warning

When the room enters in Unoccupied state, a Warning command can be executed. This allows the occupant of the room to be warned that the light might soon go off. During the Warning Time, the occupant can move to return to the Occupied state and the Occupied command is executed. If a wall switch is available in the room, the occupant can press the button to end the Warning Time. When using a direct value as the command, the command is inhibited if the command value is greater than the current output value.

Related BACnet properties: *Warning_Time*, *Warning_Command_Command* and *Warning_Command_Value*, *Occupancy_Variable_Value*.

6.6 Override Timeout

When the Occupied Mode is in Unoccupied mode, it is possible for a button or a network command to temporarily override the level of light of the room. When a command that directly affect the light level of an output of the room, a timer is started. When the timer is elapsed, the room returns to Unoccupied and the Warning and the Unoccupied commands are executed.

Related BACnet properties: *Override_Timeout*, *Occupied_Mode*, *Warning_Command_Command*, *Warning_Command_Value*, *Unoccupied_Command_Command* and *Unoccupied_Command_Value*.

6.7 Ignore Time

Once the occupancy state changes to unoccupied the ignore time is used to temporarily ignore the changes to occupied of the occupancy sensors.

Related BACnet properties: *Ignore_Time*, *Occupancy_Variable_Value*.

6.8 Hold Time

The occupancy state remains occupied for the hold time when the occupancy sensors transition to the unoccupied.

Related BACnet properties: *Hold_Time*, *Occupancy_Variable_Value*.

6.9 Occupancy Process

One or multiple occupancy sensors allow reducing or completely turn off the lighting of a room in response to its occupancy state.

Related BACnet properties: *Occupancy_Variable_Value*, *Occupied_Mode*, *Override_Timeout*, *Occupied_Mode_Command_Enable*, *Occupied_Command_Command*, *Occupied_Command_Value*, *Warning_Command_Command*, *Warning_Command_Value*, *Unoccupied_Command_Command*, *Unoccupied_Command_Value*, *Ignore_Time* and *Hold_Time*.



1. Ignore Time (motion detected)
2. Room is occupied
3. Hold Time (no motion detected)
4. Unoccupied Warning
5. Room is unoccupied

6.10 Light Sensors

The light sensors are devices that read the current illuminance and make this value available to the Room Light Control.

Related BACnet properties: *Controlled_Variable_Value*.

6.11 Setpoint

The setpoint is the desired light illuminance of the room. Different setpoints can be used depending on the occupancy state of the room.

Related BACnet properties: *Setpoint_Occupied* and *Setpoint_Unoccupied*.

6.12 Daylight Harvesting

The daylight harvesting systems use daylight to compensate for the artificial electric lighting needed to properly illuminate a room. Daylight harvesting strategies help reduce energy consumption.

Related BACnet properties: *Controlled_Variable_Value*, *Setpoint_Occupied* and *Setpoint_Unoccupied*.

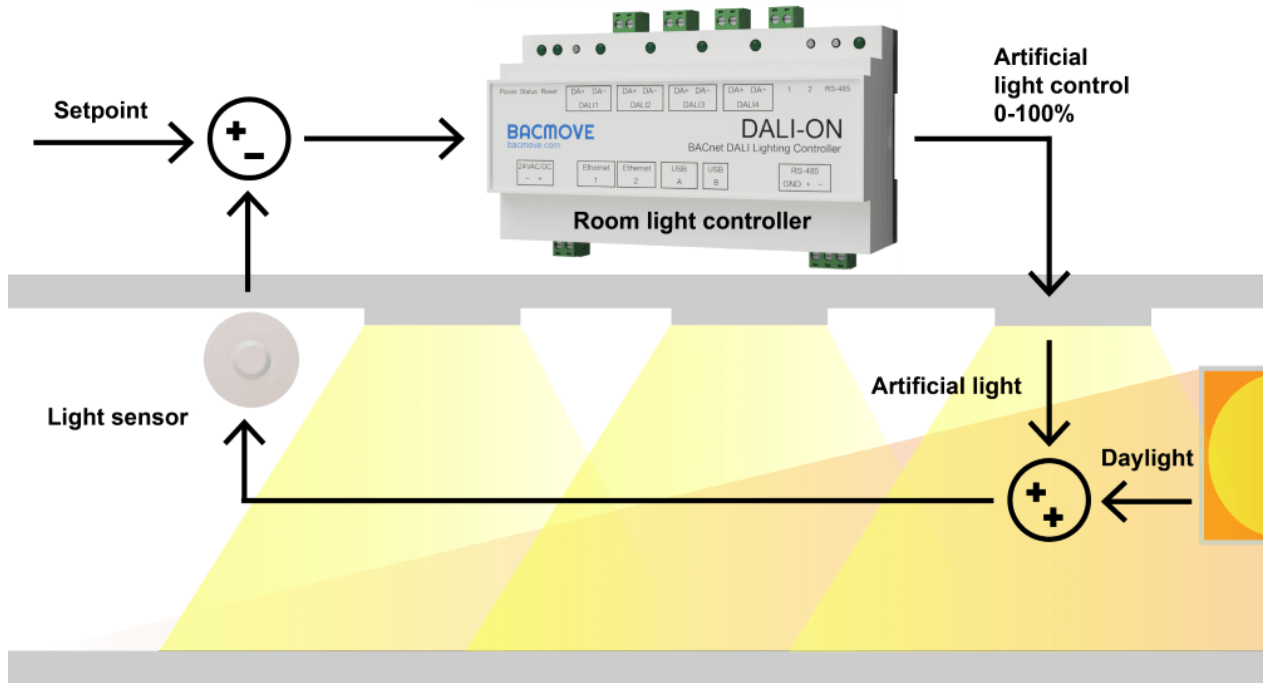

6.13 Multiple Lighting Zones

The multiple lighting zones functionality allows managing two separate lighting zones within a single Room Light Control. Typically, the Output 1 zone is situated towards the interior of the building, while the Output 2 zone is closer to the windows. Depending on the level of natural light entering the room, the Output 1 zone may need to be brighter to maintain even illumination across the space.

The configuration property *Lamp_2_Offset*, allows to set the maximum variance between the two lighting zones. The *Lamp_2_Limit* property determines the light level at which the output values for both zones become the same.

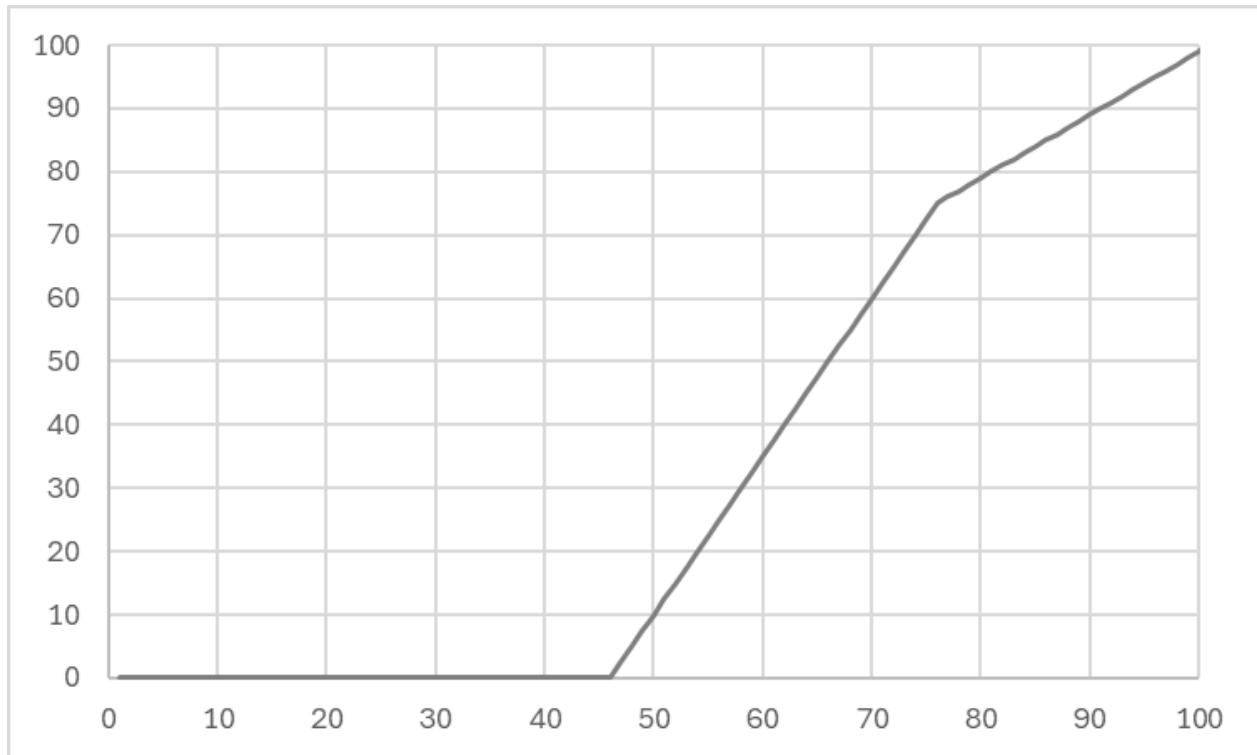

In this example, the *Lamp_2_Offset* is set to 45, and the *Lamp_2_Limit* is set to 75.

6.14 Demand Response

The demand response allows to limit the level of light of the room.

Related BACnet properties: *Demand_Response_Value*.

6.15 Schedules

For internal schedules, a Commander can be set as the schedule destination to manage the Occupied Mode. When using an external schedule via BACnet, the Command property of the Room Light Control serves to control the Occupied Mode.

6.16 Web Interface

6.16.1 Room Light Control

This page list all the available Room Light Control. It also indicates the current states of the occupancy, light sensors and outputs.

6.16.2 Room Light Control Configuration

This page allows configuring a Room Light Control. Refer to the associated BACnet Loop object for more information about the different parameters.

6.16.3 Room Light Control States

This page displays the internal states and timers of the Room Light Control, providing valuable insights into the operations and status of the Room Light Control, aiding understanding of its functioning.

6.17 BACnet Interface

To visualize the states and configure the Room Light Control, use the Loop objects.

The properties of the Loop objects are also available via the objects; *Analog Value - Room Light Control* and *Multi-State Value Object - Room Light Control*.

7 Schedule

The schedules support both time-based events and astronomical time clock events, allowing commands to be automatically executed according to user-defined programming.

It is crucial to ensure that the local time and daylight saving time settings are correctly configured. Accurate time settings are key for the precise calculation of astronomical events, allowing commands to be executed at the correct moments relative to sunrise and sunset.

For astronomical events, the local latitude and longitude must be configured. These events can occur at either sunrise or sunset. In addition, an offset and boundary time can be set. The offset allows the event to trigger up to 120 minutes before or after the sunrise or sunset time. The boundary defines the earliest and latest times for the astronomical event to take place.

8 Commander

The Commanders allow sending multiple commands in sequence. The sequence can be executed once, executed a number of times or executed until stopped manually.

The Commanders can be started or stopped from a schedule, a DALI-2 button, BACnet or the web interface.

The commands can be used to control one of the following:

- Control the light intensity of a group or channel.
- Send a command to a group or channel (Recall Scene, Recall Min Level, etc.).
- Control the colour of group or channel.
- Enable or disable a DALI-2 sensor or button.
- Send a command to a Room Light Control (Start Daylight Harvesting, Stop Demand Response, etc.).
- Enable or disable a schedule.
- Start or stop the execution of another commander.

The screenshot shows the configuration page for 'Commander 01'. It includes a 'Parameters' section with a 'Name' field (set to 'Commander 01') and an 'Execute Count' dropdown (set to '1'). Below is a 'Steps' table with 5 rows:

	Destination Type	Destination	Value	Delay (s)
1	Input - Command	In 4-31 OC-1 (Channel 4 / Input Device 31)	Sensor Command Allowed - Off Disable	0
2	Group, Channel	Group 4-01 (Channel 4 / Group 01)	80	0
3	RLC - Command	RLC 49 (RLC 49)	Start Daylight Harvesting	0
4	Group, Channel - Command	Group 4-02 (Channel 4 / Group 02)	Recall Scene 1	0
5	Disabled			

8.1 Specifications

There are 64 commanders that can execute up to 12 commands each.

Considering that a command can be configured to start another commander, the total number of commands for a single commander Start can be extended beyond the limitation of 12 command for a single commander.

8.2 Parameters

8.2.1 Name

The name of the commander is limited to 16 characters.

8.2.2 Execute Count

The number of executions of the commander. This also allows disabling the commander.

8.2.3 Steps

The list of commands to be executed.

8.2.3.1 Destination Type

The destination type.

Destination Type	Description
Disabled	Disabled
Group, Channel	Lighting intensity
Group, Channel - Command	Command for lighting
Group, Channel - Colour	Lighting colour
Input Device	Command for sensor and button
RLC - Command	Command for a Room Light Control
Schedule - Command	Command for a Schedule
Commander - Command	Command for a Commander
Commanders - Command	Command for the Commanders

8.2.3.1.1 Disabled

The step is ignored.

8.2.3.1.2 Group, Channel

The value is the light intensity for a group or channel.

8.2.3.1.3 Group, Channel - Command

For the list of available commands refer to the section “Multi-State Output Object - Command Control of Lamp, Group and Channel”.

8.2.3.1.4 Group, Channel - Colour

The value is the light intensity and colour for a group or channel.

8.2.3.1.5 Input - Command

Allows to enable or disable a DALI-2 sensor or button.

8.2.3.1.6 RLC - Command

For the list of available commands refer to the property section “Command” of the “Loop Object - Room Light Control”.

8.2.3.1.7 Schedule - Command

Allows to enable or disable a schedule.

8.2.3.1.8 Commander - Command

Allows to start or stop a specific Commander. The destination is a single Commander and the value is the command Start or Stop for this Commander.

8.2.3.1.9 Commanders - Command

Allows to start or stop a Commander.

8.2.3.2 Fade Time

The fade time used by the command with the destination type Group, Channel.

8.2.3.3 Delay

The delay in seconds before the execution of the step.

9 USB Console

9.1 USB Connector

The DALION has a Mini-B USB connector. Once connected to a computer, access to a serial command-line interface is available.

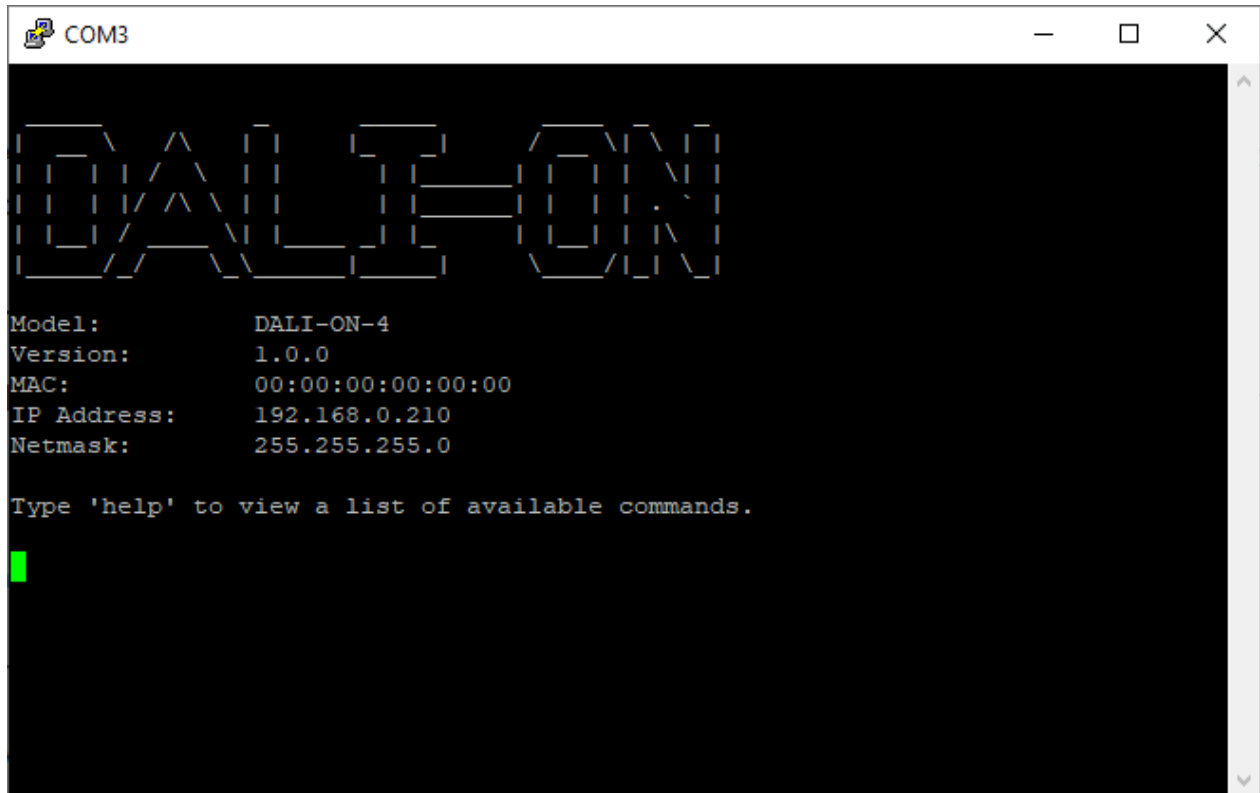

```
COM3
DALION
Model:          DALI-ON-4
Version:        1.0.0
MAC:            00:00:00:00:00:00
IP Address:     192.168.0.210
Netmask:        255.255.255.0

Type 'help' to view a list of available commands.
█
```

The command-line interface is accessible with serial console software such as PuTTY on a computer.

Several commands are available to view and change the settings, as well as to view system statistics.

Please note that strings cannot contain spaces.

9.2 Serial Console Settings

Name	Value
Speed (baudrate)	115200
Data bits	8
Stop bits	1
Parity	None

9.3 Commands General

9.3.1 help

Lists the available commands.

9.3.2 version

Displays the system version.

9.3.3 reboot

Reboots the system.

9.3.4 factorydefault

Clears all settings and commissioning data.

9.3.5 date

Displays the date and time of the system.

9.3.6 ping

Pings an IPv4 address. Follow this command with an IPv4 address.

9.3.7 status

Displays the status of the system.

9.3.8 ip [addr|a]

Displays the IP network information.

Ex.: ip a

9.4 Commands Statistics

9.4.1 stip

Displays the statistics of the IP network.

9.4.2 stbacnetip

Displays the statistics of the BACnet/IP.

9.4.3 stdali

Displays the statistics of the DALI.

9.4.4 `stdalianalyzer channel`

Displays the statistics of the DALI analyzer for the specified channel.

Ex.: `stdalianalyzer 1`

9.4.5 `sttcp`

Displays the statistics of the TCP network.

9.4.6 `studp`

Displays the statistics of the UDP.

9.4.7 `starp`

Displays the statistics of the ARP.

9.4.8 `sticmp`

Displays the statistics of the ICMP protocol.

9.4.9 `starptable`

Displays the ARP table.

9.4.10 `steth`

Displays the Ethernet registers.

9.4.11 `logread`

Displays the system log.

9.5 `Commands System Settings`

9.5.1 `setsystem`

Modifies the system settings. Follow this command with one of the following parameters. Follow the parameter with the value to assign.

Ex.: `setsystem username admin`

9.5.1.1 `username`

Username (16 characters maximum).

9.5.1.2 `password`

Password (16 characters maximum).

9.6 `Commands IP Settings`

9.6.1 `setip`

Modifies the IP settings. Follow this command with one of the following parameters. Follow the parameter with the value to assign.

Ex.: `setip source static`

9.6.1.1 *source [static/dhcp]*

IP source, DHCP or static.

Ex.: `setip source static`

9.6.1.2 *address*

IPv4 address.

Ex.: `setip address 192.168.0.100`

9.6.1.3 *netmask*

Netmask.

Ex.: `setip netmask 255.255.255.0`

9.6.1.4 *gateway*

Default gateway.

Ex.: `setip gateway 192.168.0.1`

9.6.1.5 *speed [Auto/10F/10H/100F/100H]*

Link speed.

Ex.: `setip speed auto`

9.6.1.6 *dns1*

First domain name server.

Ex.: `setip dns1 8.8.8.8`

9.6.1.7 *dns2*

Second domain name server.

9.6.1.8 *hostname*

Hostname (32 characters maximum).

9.7 Commands BACnet/IP Settings

9.7.1 **setbacnetip**

Modifies the BACnet/IP settings. Follow this command with one of the following parameters. Follow the parameter with the value to assign.

Ex.: `setbacnetip deviceid 1000`

9.7.1.1 *deviceid*

The BACnet Device ID.

Ex.: `setbacnetip deviceid 1000`

9.7.1.2 *devicename*

The BACnet Device name (32 characters maximum).

Ex.: `setbacnetip devicename DALION`

9.7.1.3 *devicedescription*

The BACnet Device description (32 characters maximum).

9.7.1.4 *devicelocation*

The BACnet Device location (32 characters maximum).

9.7.1.5 *apdtimeout*

APDU timeout in milliseconds (default: 3000).

9.7.1.6 *apduretries*

The number of APDU retries (default: 3).

9.7.1.7 *udpport*

UDP Port (default: 47808).

9.7.1.8 *bbmdip*

BBMD IPv4 address.

9.7.1.9 *bbmdport*

BBMD UDP port.

9.7.1.10 *fdelay*

Foreign device registration delay in seconds.

10 DALION Tool

10.1 Overview

The DALION Tool software for is a Windows graphic tool to help with configurations and setups of the DALION lighting controller.

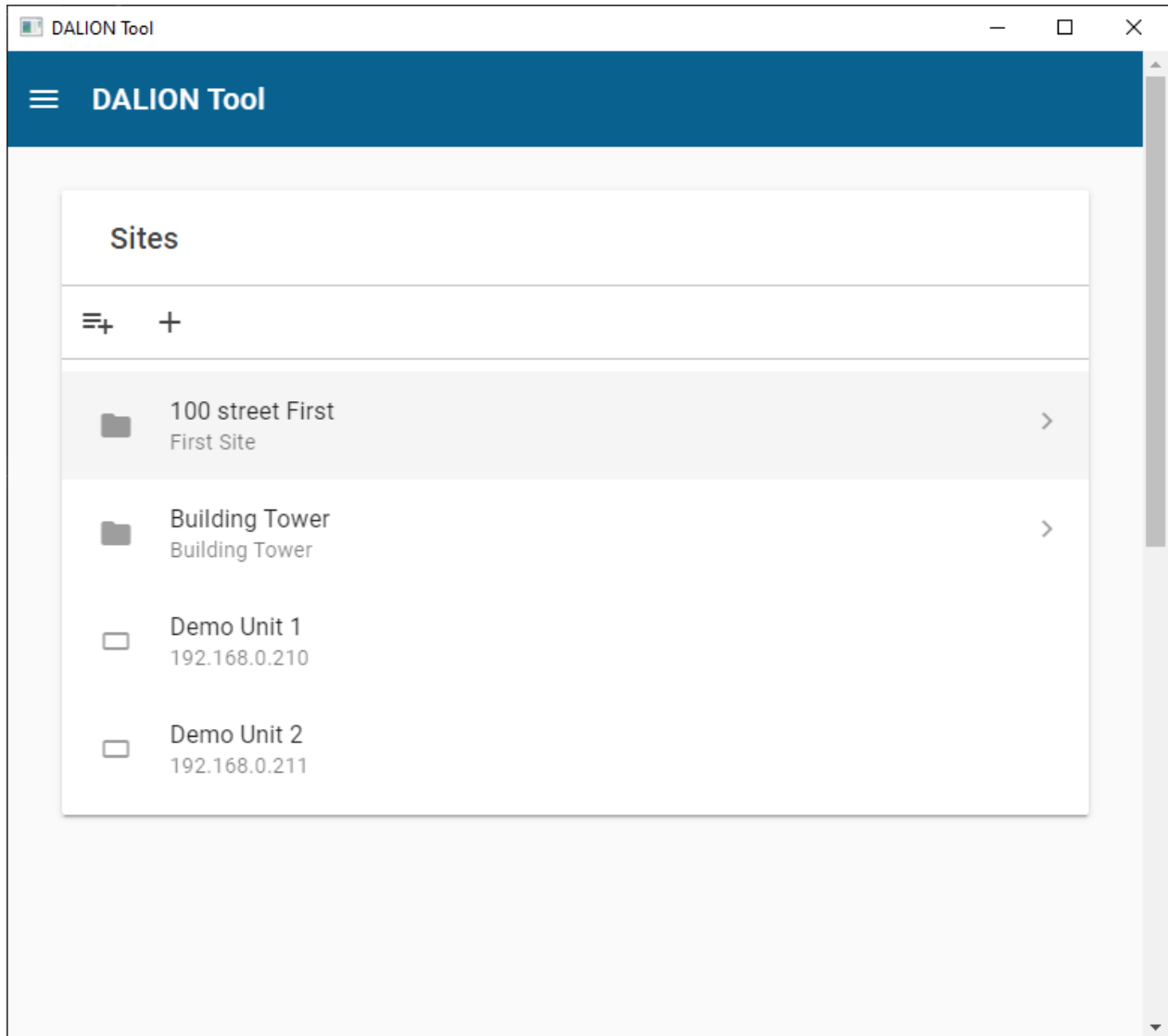

10.1.1 Installation

- Download the DALION Tool from the website bacmove.com
- Install the DALION Tool on the computer by following the instruction in the installation setup software.

10.2 Menu

10.2.1 Home

The main window of the DALION Tool.

10.2.2 About

Displays the version of the DALION Tool.

10.3 Sites

The DALION Tool can keep the network configuration and credentials of several DALION for easier access later.

10.3.1 Folder

The folders allow storing similar DALION together. For example, folders can be created for each floor of a building.

10.3.1.1 Add folder

This button allows to create a new folder in the current folder.

10.3.1.2 Rename folder

This button allows renaming the current folder.

10.3.1.3 Delete folder

This button allows deleting the current folder.

10.3.1.4 Name

A friendly name for the folder.

10.3.1.5 Description

A description of the folder and displayed below its name.

10.3.2 Device

The DALION device. Multiple DALION can be present in a folder. A device defines the network configuration and credentials to access a DALION.

10.3.2.1 Add device

This button allows to create a new device.

10.3.2.2 Name

A friendly name for the DALION.

10.3.2.3 Description

A description of the DALION and displayed below its name.

10.3.2.4 IP Address

The network IP address of the DALION.

10.3.2.5 Username

The username used to connect to the DALION.

10.3.2.6 Password

The password used to connect to the DALION.

10.4 Download Backup

The Download Backup allows downloading to the computer a backup file of the DALION settings and assignments from a DALION.

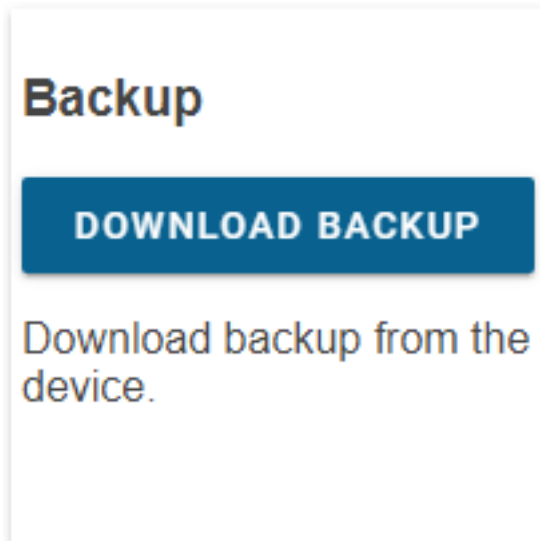

10.4.1 Preparations

- Download and install the latest version of the DALION Tool.
- Connect the computer with DALION Tool to the same network as the DALION to download backup from.

10.4.2 Download

- Press the **Download Backup** button in the DALION Tool.
- Select a folder on the computer where the backup file will be downloaded to.
- Wait for the download to complete.

10.5 Restore Backup

The Restore Backup allows uploading from the computer a backup file of the DALION settings and assignments to a DALION.

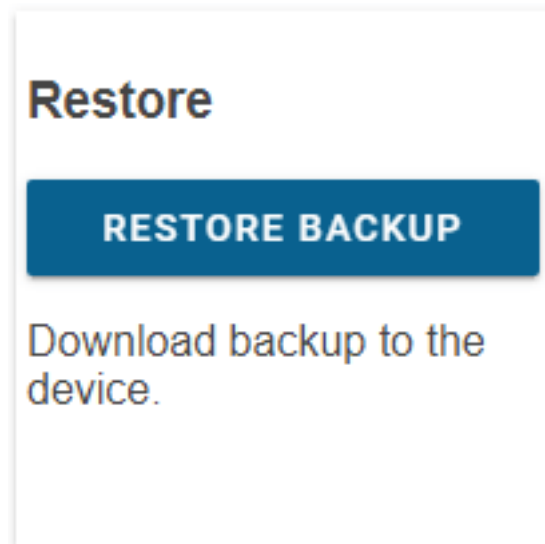

10.5.1 Preparations

- Download and install the latest version of the DALION Tool.
- Connect the computer with DALION Tool to the same network as the DALION to upload the backup to.

10.5.2 Restore

- Press the **Restore Backup** button in the DALION Tool.
- Select a DALION backup file on the computer that will be uploaded to the DALION.
- Wait for the upload to complete.

10.6 Firmware Upgrade

The firmware upgrades are intended to provide security and functional updates to ensure that the DALION is always up to date. With the DALION Tool, it is possible to supply the DALION with the new firmware.

Firmware Upgrade

FIRMWARE UPGRADE

Upgrade the device
firmware.

10.6.1 Warnings



- MAKE SURE THE DALION HAS A STABLE POWER SUPPLY DURING THE FIRMWARE UPGRADE.
- DO NOT REMOVE THE POWER SUPPLY FROM THE DALION DURING THE FIRMWARE UPGRADE.

10.6.2 Preparations

- Download and install the latest version of the DALION Tool.
- Download the latest version of the DALION firmware.
- Connect the computer with DALION Tool to the same network as the DALION to upgrade.

10.6.3 Upgrade

- Press the **Firmware Upgrade** button in the DALION Tool.
- Select the previously downloaded DALION firmware from the computer.
- Wait for the upgrade to complete.

10.7 Pre-Commissioning

This option is not yet available.

Pre-commissioning

PRE-COMMISSIONING

Perform lamps pre-commissioning from CSV file.

11 Remote CLI Tool

11.1 Overview

The DALION Remote CLI (command-line interface) Tool is a Windows tool to help with multiple configurations and setups of the DALION lighting controller.

11.2 Commands

A list of the available commands and parameters.

11.2.1 help

Lists the available commands and parameters.

Example

```
--help
```

11.2.2 version

Displays the tool version.

Example

```
--version
```

11.2.3 ip

IP address of the DALION controller.

Example

```
--ip 192.168.0.210
```

11.2.4 channel

DALI channel number between 1 and 4. It is possible to use a single channel or have multiple channels.

Example

```
# single channel  
--channel 1  
# multiple channels  
--channel [1, 2]
```

11.2.5 channelcsvfile

This parameter is a path to a CSV (comma-separated values) file. CSV file can be created in a spreadsheet software like Microsoft Excel or directly as a text file.

It is possible to use a single channel or have multiple channels.

Example

```
# single channel
--channelcsvfile "[\"C:\\channel1_lamps.csv\"]"
# multiple channels
--channelcsvfile "[\"C:\\channel1_lamps.csv\", \"C:\\channel2_lamps.csv\"]"
```

11.2.6 channelgroupscsvfile

This parameter is a path to a CSV (comma-separated values) file. CSV file can be created in a spreadsheet software like Microsoft Excel or directly as a text file.

It is possible to use a single channel or have multiple channels.

Example

```
# single channel
--channelgroupscsvfile "[\"C:\\channel1_groups.csv\"]"
# multiple channels
--channelgroupscsvfile "[\"C:\\channel1_groups.csv\", \"C:\\channel2_groups.csv\"]"
```

11.2.7 channelinputscsvfile

This parameter is a path to a CSV (comma-separated values) file. CSV file can be created in a spreadsheet software like Microsoft Excel or directly as a text file.

It is possible to use a single channel or have multiple channels.

Example

```
# single channel
--channelinputscsvfile "[\"C:\\channel1_inputs.csv\"]"
# multiple channels
--channelinputscsvfile "[\"C:\\channel1_inputs.csv\", \"C:\\channel2_inputs.csv\"]"
```

11.2.8 action

Action to perform on the DALION.

Action	Description
setup_channel	Pre-commissioning of DALI lamps
get_backup	Download backup files from the controller
put_backup	Upload backup files to the controller
push_firmware	Allows upgrading of the controller firmware

11.2.9 firmwarefile

Path to a firmware file.

11.2.10 backupfileouttype

Type of backup output; directory or zip. The default value is directory.

11.2.10.1 directory

Backup files are created in the directory.

11.2.10.2 zip

A ZIP file containing all the backup is created in the directory.

11.2.11 backupconfig

Select the backup. By default all backups are used. Multiple configurations can be passed.

Value	Description
systemconfig	Controller system configuration
dali1	Configuration and commissioning of DALI channel 1
dali2	Configuration and commissioning of DALI channel 2
dali3	Configuration and commissioning of DALI channel 3
dali4	Configuration and commissioning of DALI channel 4

Example

```
--backupconfig ["systemconfig", "dali2"]
```

11.2.12 backupfileout

The directory where the backup files are copied.

Example

```
backupfileout "C:\backup\"
```

11.2.13 backupfilein

The ZIP or TAR configuration file to upload to the controller.

Example

```
backupfilein "C:\backup\backup_DALIION.zip"
```

11.3 Channel Lamps CSV File Format

The format of the CSV file is as follows.

```
#DALION DALI CHANNEL CSV,,,,,,,,,
#dali-channel-csv-version: 1,,,,,,,,,
#channel,lampIndex,shortAddress,name,groups,powerOnLevel,systemFailureLevel,m
inLevel,maxLevel,fadeRate,fadeTime,scenes
4,1,1,AABBCC,"[1,4]",10,30,0.1,100,4,2,"[100, 20, null, 80]"
```

11.3.1 First line

File description.

```
#DALION DALI CHANNEL CSV,,,,,,,,,,,,,
```

11.3.2 Second line

File content version. The version number should be 1.

```
#dali-channel-csv-version: 1,,,,,,,,,,,,,
```

11.3.3 Third line

File content header. Should have the following columns.

```
#channel,lampIndex,shortAddress,name,groups,powerOnLevel,systemFailureLevel,minLevel,maxLevel,fadeRate,fadeTime,scenes
```

Column

channel

lampIndex

shortAddress

name

groups

powerOnLevel

systemFailureLevel

minLevel

maxLevel

fadeRate

fadeTime

scenes

11.3.4 Columns

The lamp data columns.

11.3.4.1 *channel*

The DALI channel number of the DALION, starting at zero (0).

11.3.4.2 *lampIndex*

The DALI lamp index in the DALION starting at zero (0). Number between 0 and 63.

11.3.4.3 *shortAddress*

The DALI lamp short address between 0 and 63. A value of null can be used not to modify the short address.

11.3.4.4 *name*

The name of the DALI lamp that will appear in the DALION and BACnet network.

11.3.4.5 *groups*

The DALI groups that the lamp takes part of. The format is “[GROUP_NUMBER, GROUP_NUMBER]”. Replace GROUP_NUMBER by any group number between 0 and 15.

DALI default value is “[]”.

11.3.4.6 *powerOnLevel*

The DALI lamp parameter “POWER ON LEVEL” in percent. For DALI MASK use the value null.

DALI default value is **100**.

11.3.4.7 *systemFailureLevel*

The DALI lamp parameter “SYSTEM FAILURE LEVEL” in percent. For DALI MASK use the value null.

DALI default value is **100**.

11.3.4.8 *minLevel*

The DALI lamp parameter “MIN LEVEL” in percent. For DALI MASK use the value null.

11.3.4.9 *maxLevel*

The DALI lamp parameter “MAX LEVEL” in percent. For DALI MASK use the value null.

DALI default value is **100**.

11.3.4.10 *fadeRate*

The DALI lamp parameter “FADE RATE”. Should be a number between 1 and 15.

DALI default value is **7**.

Value	Fade Rate (steps/seconds)
1	358
2	253
3	179
4	127
5	89.4
6	63.3
7	44.7
8	31.6
9	22.4
10	15.8
11	11.2
12	7.9
13	5.6
14	4.0
15	2.8

11.3.4.11 fadeTime

The DALI lamp parameter “FADE TIME”. Should be a number between 0 and 15.

DALI default value is **0**.

Value	Fade Time (seconds)
0	No fade
1	0.7
2	1.0
3	1.4
4	2.0
5	2.8
6	4.0
7	5.7
8	8.0
9	11.3
10	16.0
11	22.6
12	32.0
13	45.3
14	64.0
15	90.5

11.3.4.12 scenes

The values in percent of the different light intensity scenes of the lamp. For DALI MASK use the value null. The format is “[SCENE_VALUE, SCENE_VALUE]”. Replace SCENE_VALUE by the scene value in percent. Each index represents the value of the scene X for that index.

DALI default value is “[]”.

11.4 Channel Groups CSV File Format

The format of the CSV file is as follows.

```
#DALION DALI CHANNEL GROUPS CSV,,
#dali-channel-groups-csv-version: 1,,
#channel,groupIndex,name
0,0,"DALI 1-4-BD1-G0"
```

11.4.1 First line

File description.

```
#DALION DALI CHANNEL GROUPS CSV,,
```

11.4.2 Second line

File content version. The version number should be 1.

```
#dali-channel-groups-csv-version: 1,,
```

11.4.3 Third line

File content header. Should have the following columns.

```
#channel,groupIndex,name
```

Column

channel

groupIndex

name

11.4.4 Columns

The group data columns.

11.4.4.1 channel

The DALI channel number of the DALION, starting at zero (0).

11.4.4.2 groupIndex

The DALI group index in the DALION starting at zero (0). Number between 0 and 15.

11.4.4.3 name

The name of the DALI group that will appear in the DALION and BACnet network.

11.5 Channel Inputs CSV File Format

The format of the CSV file is as follows.

```
#DALION DALI CHANNEL INPUTS CSV,,,,,,,,,,,,,,,,,,,,,  
#dali-channel-inputs-csv-version: 1,,,,,,,,,,,,,,,,,,,,,  
#channel,inputIndex,shortAddress,name,numberOfInstances,instancesType,instanc  
esResolution,instancesClassButtonRepeatTime,instancesClassButtonOptions,insta  
ncesClassButtonPresTime,instancesClassButtonDestination,instancesClassButton  
Command,instancesClassButtonValue1,instancesClassButtonValue2,instancesClassO  
ccupancySensorHoldTime,instancesClassOccupancySensorDeadTime,instancesClassOc  
cupancySensorReportTime,instancesClassLightSensorHysteresis,instancesClassLig  
htSensorHysteresisMin  
0,1,7,Input Button 1,7,"[1, 1, 1, 1, 1, 1, 1, 1]", "[0, 0, 0, 0, 0, 0, 0, 0]", "[1,  
1, 1, 1, 1, 1, 1, 1]", "[0, 0, 0, 0, 0, 0, 0, 0]", "[0, 0, 0, 0, 0, 0, 0, 0]", "[1, 1, 1,  
1, 1, 1, 1, 1]", "[1, 1, 1, 1, 1, 1, 1, 1]", "[0, 0, 0, 0, 0, 0, 0, 0]", "[0, 0, 0, 0, 0,  
0, 0]", [], [], [], [], [], []
```

11.5.1 First line

File description.

```
#DALION DALI CHANNEL INPUTS CSV,,,,,,,,,,,,,,,,,,,,,
```

11.5.2 Second line

File content version. The version number should be 1.

```
#dali-channel-inputs-csv-version: 1,,,,,,,,,,,,,,,,,,,,,
```

11.5.3 Third line

File content header. Should have the following columns.

```
#channel,inputIndex,shortAddress,name,numberOfInstances,instancesType,instancesResolution,instancesClassButtonRepeatTime,instancesClassButtonOptions,instancesClassButtonPressTime,instancesClassButtonDestination,instancesClassButtonCommand,instancesClassButtonValue1,instancesClassButtonValue2,instancesClassOccupancySensorHoldTime,instancesClassOccupancySensorDeadTime,instancesClassOccupancySensorReportTime,instancesClassLightSensorHysteresis,instancesClassLightSensorHysteresisMin
```

Column

channel

inputIndex

shortAddress

name

numberOfInstances

instancesType

instancesResolution

instancesClassButtonRepeatTime

instancesClassButtonOptions

instancesClassButtonPressTime

instancesClassButtonDestination

instancesClassButtonCommand

instancesClassButtonValue1

instancesClassButtonValue2

instancesClassOccupancySensorHoldTime

instancesClassOccupancySensorDeadTime

instancesClassOccupancySensorReportTime

instancesClassLightSensorHysteresis

instancesClassLightSensorHysteresisMin

11.5.4 Columns

The input data columns.

11.5.4.1 *channel*

The DALI channel number of the DALION, starting at zero (0).

11.5.4.2 *inputIndex*

The DALI input index in the DALION starting at zero (0). Number between 0 and 31.

11.5.4.3 *shortAddress*

The DALI lamp short address between 0 and 63. A value of null can be used not to modify the short address.

11.5.4.4 *name*

The name of the DALI input that will appear in the DALION and BACnet network.

11.5.4.5 *numberOfInstances*

The number of instances.

11.5.4.6 *instancesType*

The type of instance. The format is “[INSTANCE_TYPE, INSTANCE_TYPE]”. Replace INSTANCE_TYPE by one of the following supported instance type numbers.

Name	Number
Push-Button	1
Occupancy Sensor	3
Light Sensor	4

11.5.4.7 *instancesResolution*

The instance resolution number. The format is “[INSTANCE_RESOLUTION, INSTANCE_RESOLUTION]”. Replace INSTANCE_RESOLUTION by the instance resolution number.

11.5.4.8 *instancesClassButtonRepeatTime*

For push-button. The instance repeat time. The format is “[REPEAT_TIME, REPEAT_TIME]”. Replace REPEAT_TIME by the instance repeat time.

11.5.4.9 *instancesClassButtonOptions*

For push-button. The instance options. The format is “[OPTIONS, OPTIONS]”. Replace OPTIONS by the instance options.

11.5.4.10 *instancesClassButtonPressTime*

For push-button. The instance press time. The format is “[PRESS_TIME, PRESS_TIME]”. Replace PRESS_TIME by the instance press time.

11.5.4.11 *instancesClassButtonDestination*

For push-button. The instance destination. The format is “[DESTINATION, DESTINATION]”. Replace DESTINATION by the instance destination.

11.5.4.12 *instancesClassButtonCommand*

For push-button. The instance command. The format is “[COMMAND, COMMAND]”. Replace COMMAND by the instance command.

11.5.4.13 *instancesClassButtonValue1*

For push-button. The instance value 1. The format is “[VALUE_1, VALUE_1]”. Replace VALUE_1 by the instance value 1.

11.5.4.14 *instancesClassButtonValue2*

For push-button. The instance value 2. The format is “[VALUE_2, VALUE_2]”. Replace VALUE_2 by the instance value 2.

11.5.4.15 *instancesClassOccupancySensorHoldTime*

For occupancy sensor. The instance hold time. The format is “[HOLD_TIME, HOLD_TIME]”. Replace HOLD_TIME by the instance hold time.

11.5.4.16 *instancesClassOccupancySensorDeadTime*

For occupancy sensor. The instance dead time. The format is “[DEAD_TIME, DEAD_TIME]”. Replace DEAD_TIME by the instance dead time.

11.5.4.17 *instancesClassOccupancySensorReportTime*

For occupancy sensor. The instance report time. The format is “[REPORT_TIME, REPORT_TIME]”. Replace REPORT_TIME by the instance report time.

11.5.4.18 *instancesClassLightSensorHysteresis*

For light sensor. The instance hysteresis. The format is “[HYSTERESIS, HYSTERESIS]”. Replace HYSTERESIS by the instance hysteresis.

11.5.4.19 *instancesClassLightSensorHysteresisMin*

For light sensor. The instance hysteresis minimum. The format is “[HYSTERESIS_MIN, HYSTERESIS_MIN]”. Replace HYSTERESIS_MIN by the instance hysteresis minimum.

11.6 Example of command

11.6.1 DALI Pre-commissioning configuration

To perform offline pre-commissioning of DALI lamps of a channel the following parameters are used.

Parameters	Value
action	setup_channel
ip	IP address of the controller
channel	Channel to modify
channelcsvfile	CSV file for the DALI lamps
channelgroupscsvfile	CSV file for the DALI groups
channelinputscsvfile	CSV file for the DALI inputs

Example

```
lwgwu-cli.exe --action setup_channel --ip 192.168.0.210 --channel 1 --  
channelcsvfile "[\"C:\\channel1.csv\"]"
```

11.6.2 Download Backup

To download the backup files from the controller the following parameters are used.

Parameters	Value
action	get_backup
ip	IP address of the controller
backupfileouttype	Type of backup output
backupconfig	Backup config files to download
backupfileout	Directory where the backup is copied

Example

```
lwgwu-cli.exe --action get_backup --ip 192.168.0.210 --backupfileouttype zip --backupfileout "C:\\backup\\"
```

11.6.3 Upload Backup

To upload a backup file to the controller the following parameters are used.

Parameters	Value
action	put_backup
ip	IP address of the controller
backupfilein	Path to the backup file to upload

Example

```
lwgwu-cli.exe --action put_backup --ip 192.168.0.210 --backupfilein "C:\\backup\\backup_DALI-ON.zip"
```

11.6.4 Firmware Upgrade



- MAKE SURE THE DALION HAS A STABLE POWER SUPPLY DURING THE FIRMWARE UPGRADE.
- DO NOT REMOVE THE POWER SUPPLY FROM THE DALION DURING THE FIRMWARE UPGRADE.

To upgrade the firmware of the controller the following parameters are used.

Parameters	Value
action	push_firmware
ip	IP address of the controller
firmwarefile	Path to the firmware file to upload

Example

```
lwgwu-cli.exe --action push_firmware --ip 192.168.0.210 --firmwarefile  
"C:\\firmware\\DALION_1.0.0.bin"
```

12 API

12.1 Overview

Definition of the DALION API.

Any programming language capable of sending HTTP GET requests can interact with the DALI lamps through the DALION.

The data are transferred in the JSON format and with URL parameters.

For example, the HTTP GET requests can be sent via a command line script with the cURL command.

```
curl -X "GET"
"http://192.168.0.210/api/v100/dali_devices.ssi?action=set_level&ch=1&sa=3&da=1000"
```

12.2 Requests

12.2.1 Sets lamp, group or channel light intensity

Allows modifying the light intensity of a lamp or multiple lamps.

This request uses the DALI short address of the lamp. The short address of a lamp index can be retrieved with the request get or get_device.

To modify a lamp light intensity with its lamp index the request set_device must be used.

12.2.1.1 Request URL

```
/api/v100/dali_devices.ssi?action=set_level&ch={channel}&sa={short -
address}&da={value-in-percent}
```

12.2.1.2 Parameters

Name	Value
action	set_level
ch	The number of the DALI channel, 1-4
sa	The DALI short address, 0-63. Multiple addresses can be passed in an array [sa, sa, ...]. The array must be URL encoded.
gi	The DALI group, 0-15 or -1 for the broadcast. Multiple groups can be passed in an array [gi, gi, ...]. The array must be URL encoded.
da	The value in percent multiplied by 10. For example; 0 = 0%, 1 = 0.1%, 1000 = 100%.

12.2.1.3 Examples

Sets to 100% the light intensity of the DALI lamp with the short address 3 on the channel 1.

```
/api/v100/dali_devices.ssi?action=set_level&ch=1&sa=3&da=1000
```

Sets to 100% the light intensity of the DALI group 3 on the channel 1.

```
/api/v100/dali_devices.ssi?action=set_level&ch=1&gi=3&da=1000
```

Sets to 70% the light intensity of the groups 1 and 10 on the channel 1.

```
/api/v100/dali_devices.ssi?action=set_level&ch=1&gi=%5B1%2C%2010%5D&da=700
```

Sets to 20% the light intensity of the entire DALI channel 1.

```
/api/v100/dali_devices.ssi?action=set_level&ch=1&gi=-1&da=200
```

12.2.2 Get the list of lamps and control devices

Allows retrieving the list of the devices for a channel.

12.2.2.1 Request URL

```
/api/v100/dali_devices.ssi?action=get&ch={channel}
```

12.2.2.2 Parameters

Name	Value
------	-------

action	get
--------	-----

ch	The number of the DALI channel, 1-4
----	-------------------------------------

12.2.2.3 Response

The list of the assigned and unassigned DALI lamps, the list of the assigned and unassigned DALI-2 control devices.

```
{
  "type": "dali_devices",
  "action": "get",
  "data": {
    "status": 0,
    "mode": 0,
    "devices": {
      "devices": [{
        "ii": "0",
        "na": "Lamp 1-00",
        "sa": 3,
        "fl": 1,
        "dt": [6, 255],
        "al": 0,
        "si": 0
      }]
    },
    "unassigned_devices": {
      "devices": []
    },
    "control_devices": {
```



```

"devices": [{
  "ii": "0",
  "na": "Input 1-00",
  "sa": 1,
  "fl": 1,
  "it": "26",
  "dt": 0,
  "al": 0,
  "si": 32,
  "os": 255,
  "ls": 52
}, {
  "ii": "1",
  "na": "Input 1-01",
  "sa": 3,
  "fl": 1,
  "it": "27",
  "dt": 0,
  "al": 0,
  "si": 32,
  "os": 0,
  "ls": 128
}]
},
"unassigned_control_devices": {
  "devices": []
}
}
}

```

12.2.2.3.1 action

get

12.2.2.3.2 data

Contains the DALI devices lists.

12.2.2.3.2.1 status

Value	Description
0	The DALI channel scan is currently inactive
1	The DALI channel scan has been launched and some command might not be available

12.2.2.3.2.2 mode

Value	Description
0	The DALI channel is available
1	The commands affecting DALI lamps are disabled

12.2.2.3.2.3 devices

Contains the list of assigned lamps.

12.2.2.3.2.4 devices

The list of assigned lamps.

12.2.2.3.2.5 ii

The lamp index, 0-63.

12.2.2.3.2.6 na

The name of the lamp.

12.2.2.3.2.7 sa

The DALI short address of the lamp.

12.2.2.3.2.8 fl

The flags of the lamp.

Value	Description
0	No lamp assigned for this index
1	A lamp is assigned for this index

12.2.2.3.2.9 dt

An array of the DALI supported device types of the lamp.

Value	Name
0	Fluorescent
1	Self-contained emergency
2	Discharge HID
3	Low-voltage halogen
4	Incandescent lamp
5	Conversion to DC voltage
6	LED
7	Switching relay
8	Colour
255	Not specified

12.2.2.3.2.10 al

The actual light intensity of the lamp in percent multiplied by 10. For example; 0 = 0%, 1 = 0.1%, 1000 = 100%.

12.2.2.3.2.11 si

The actual status information of the lamp.

The value 255 means communication failure with the lamp. Otherwise when the bit 2 is set it means the lamp has a problem. The other value means that the lamp is functioning normally.

12.2.2.3.2.12 unassigned_devices

The list of the unassigned devices discovered after a scan of the channel.

12.2.2.3.2.13 control_devices

The list of the control devices.

12.2.2.3.2.14 it

The supported instances type by the control device. Each bit indicates if a type is supported or not.

Bit Type

1	Push Buttons
3	Occupancy Sensor
4	Light Sensor

12.2.2.3.2.15 os

The actual occupancy state of the sensor.

Value	Name
0	Unoccupied
255	Occupied

12.2.2.3.2.16 ls

The actual light value of the sensor.

12.2.2.3.2.17 unassigned_control_devices

The list of the unassigned control devices discovered after a scan of the channel.

12.2.2.4 Examples

Gets the DALI devices of the first channel.

```
/api/v100/dali_devices.ssi?action=get&ch=1
```

12.2.3 Get lamp information

Allows retrieving the information of a lamp.

12.2.3.1 Request URL

```
/api/v100/dali_devices.ssi?action=get_device&ch={channel}&di={device-index}
```

12.2.3.2 Parameters

Name	Value
action	get_device
ch	The number of the DALI channel, 1-4
di	The lamp index, 0-63

12.2.3.3 Response

The response contains the values as well as other information like the value limitation, name, etc.

```
{
  "type": "dali_devices",
  "action": "get_device",
  "data": {
    "device": {
      "name": "Lamp 1-00",
      "types": ["6", "255"],
      "variables": [{
        "ty": "nb10",
        "id": "dval",
        "tx": "Actual Level %",
        "va": "0",
        "ph": "",
        "mi": "0",
        "ma": "1000",

```

```

    "st": "1"
  }, {
    "ty": "tx",
    "id": "na",
    "tx": "Name",
    "va": "Lamp 1-00",
    "ph": ""
  }, {
    "ty": "nb10",
    "id": "dvpl",
    "tx": "Power On Level %",
    "va": "1000",
    "ph": "MASK",
    "mi": "0",
    "ma": "1000",
    "st": "1"
  }, {
    "ty": "nb10",
    "id": "dvsl",
    "tx": "System Failure Level %",
    "va": "1000",
    "ph": "MASK",
    "mi": "0",
    "ma": "1000",
    "st": "1"
  }, {
    "ty": "nb10",
    "id": "dvn1",
    "tx": "Minimum Level %",
    "va": "1",
    "ph": "",
    "mi": "1",
    "ma": "1000",
    "st": "1"
  }, {
    "ty": "nb10",
    "id": "dvx1",
    "tx": "Maximum Level %",
    "va": "1000",
    "ph": "",
    "mi": "10",
    "ma": "1000",
    "st": "1"
  }, {
    "ty": "se",
    "id": "dvfr",

```

```
"tx": "Fade Rate steps/s",
"va": "7",
"op": [{
  "va": 1,
  "tx": "358"
}, {
  "va": 2,
  "tx": "253"
}, {
  "va": 3,
  "tx": "179"
}, {
  "va": 4,
  "tx": "127"
}, {
  "va": 5,
  "tx": "89.4"
}, {
  "va": 6,
  "tx": "63.3"
}, {
  "va": 7,
  "tx": "44.7"
}, {
  "va": 8,
  "tx": "31.6"
}, {
  "va": 9,
  "tx": "22.4"
}, {
  "va": 10,
  "tx": "15.8"
}, {
  "va": 11,
  "tx": "11.2"
}, {
  "va": 12,
  "tx": "7.9"
}, {
  "va": 13,
  "tx": "5.6"
}, {
  "va": 14,
  "tx": "4.0"
}, {
  "va": 15,
```

```

    "tx": "2.8"
  }
], {
  "ty": "se",
  "id": "dvft",
  "tx": "Fade Time seconds",
  "va": "0",
  "op": [{
    "va": 0,
    "tx": "No fade"
  }, {
    "va": 1,
    "tx": "0.7"
  }, {
    "va": 2,
    "tx": "1.0"
  }, {
    "va": 3,
    "tx": "1.4"
  }, {
    "va": 4,
    "tx": "2.0"
  }, {
    "va": 5,
    "tx": "2.8"
  }, {
    "va": 6,
    "tx": "4.0"
  }, {
    "va": 7,
    "tx": "5.7"
  }, {
    "va": 8,
    "tx": "8.0"
  }, {
    "va": 9,
    "tx": "11.3"
  }, {
    "va": 10,
    "tx": "16.0"
  }, {
    "va": 11,
    "tx": "22.6"
  }, {
    "va": 12,
    "tx": "32.0"
  }
]

```

```

    }, {
      "va": 13,
      "tx": "45.3"
    }, {
      "va": 14,
      "tx": "64.0"
    }, {
      "va": 15,
      "tx": "90.5"
    }
  ]
}, {
  "ty": "nb",
  "id": "dvgr",
  "tx": "Groups",
  "va": "0",
  "ph": "",
  "mi": "0",
  "ma": "65535",
  "st": "1"
}, {
  "ty": "nb",
  "id": "dvsa",
  "tx": "Short Address",
  "va": "1",
  "ph": "",
  "mi": "0",
  "ma": "63",
  "st": "1"
}, {
  "ty": "nb",
  "id": "dvrh",
  "tx": "Run Hours (seconds)",
  "va": "7440",
  "ph": "",
  "mi": "0",
  "ma": "2147483647",
  "st": "1"
}, {
  "ty": "nb",
  "id": "dvbi",
  "tx": "Burn-In (seconds)",
  "va": "0",
  "ph": "",
  "mi": "0",
  "ma": "2147483647",
  "st": "1"
}

```



```

    }, {
      "ty": "lt",
      "id": "bo",
      "tx": "BACnet Object",
      "va": "Analog Output/Input 0"
    }, {
      "ty": "lt",
      "id": "re",
      "tx": "Reliability",
      "va": "0 (no-fault-detected)"
    }
  ]
}
}
}

```

12.2.3.3.1 action

get_device

12.2.3.3.2 data

Contains the information of the DALI device.

12.2.3.3.3 name

The name of the lamp.

12.2.3.3.4 types

An array of the DALI supported device types of the lamp.

Value	Name
0	Fluorescent
1	Self-contained emergency
2	Discharge HID
3	Low-voltage halogen
4	Incandescent lamp
5	Conversion to DC voltage
6	LED
7	Switching relay
8	Colour
255	Not specified

12.2.3.3.5 variables

An array of lamp variables.

12.2.3.3.6 id

12.2.3.3.6.1 dval

The actual light intensity in percent multiplied by 10. For example; 0 = 0%, 1 = 0.1%, 1000 = 100%.

12.2.3.3.6.2 na

The name of the lamp.

12.2.3.3.6.3 dvpl

The Power On Level in percent multiplied by 10. For example; 0 = 0%, 1 = 0.1%, 1000 = 100%.

12.2.3.3.6.4 dvsf

The System Failure Level in percent multiplied by 10. For example; 0 = 0%, 1 = 0.1%, 1000 = 100%.

12.2.3.3.6.5 dvnf

The Minimum Level in percent multiplied by 10. For example; 0 = 0%, 1 = 0.1%, 1000 = 100%.

12.2.3.3.6.6 dvxl

The Maximum Level in percent multiplied by 10. For example; 0 = 0%, 1 = 0.1%, 1000 = 100%.

12.2.3.3.6.7 dvfr

The Fade Rate value.

Value	Fade Rate (steps/seconds)
1	358
2	253
3	179
4	127
5	89.4
6	63.3
7	44.7
8	31.6
9	22.4
10	15.8
11	11.2
12	7.9
13	5.6
14	4.0
15	2.8

12.2.3.3.6.8 dvft
The Fade Time value.

Value	Fade Time (seconds)
0	No fade
1	0.7
2	1.0
3	1.4
4	2.0
5	2.8
6	4.0
7	5.7
8	8.0
9	11.3
10	16.0
11	22.6
12	32.0
13	45.3
14	64.0
15	90.5

12.2.3.3.6.9 dvgr

It represents the DALI variables “GROUP_0_8” and “GROUP_9_15” concatenated in a 16 bit.

12.2.3.3.6.10 dvsa

The DALI short address of the lamp.

12.2.3.3.6.11 dvrh

Number of seconds where the lamp was on.

12.2.3.3.6.12 dvbi

Number of seconds remaining to the burn-in.

12.2.3.3.6.13 bo

The BACnet object associated with the lamp.

12.2.3.3.6.14 re

The reliability of the lamp.

12.2.3.4 Examples

Get the lamp 0 for the channel 1.

```
/api/v100/dali_devices.ssi?action=get_device&ch=1&di=0
```

12.2.4 Set lamp information

Allows setting the information of a lamp, group or channel.

12.2.4.1 Request URL

```
/api/v100/dali_devices.ssi?action=set_device&ch={channel}&di={device-index}&device={device-data}
```

12.2.4.2 Parameters

Name	Value
action	set_device
ch	The number of the DALI channel, 1-4
di	The lamp index, 0-63
gi	The DALI group, 0-15 or -1 for the broadcast
device	The variable of the lamp to modify. Multiple variables can be passed in an array [data, data, ...]. The array must be URL encoded.

12.2.4.2.1 device

The array of the device information to modify. The array must be URL encoded.

12.2.4.2.1.1 id

Refers to the id of the get_device request.

12.2.4.2.1.2 va

Refers to the value of the get_device request.

Uses the same data type as the value from the request get_device. Most values are of the type string.

12.2.4.3 Response

```
{
  "type": "dali_devices",
  "action": "set_device",
  "data": {
    "type": "sni",
    "result": "success",
    "result_code": 0
  }
}
```

12.2.4.4 Examples

Sets the name of the lamp 0 for the channel 1.

```
/api/v100/dali_devices.ssi?action=set_device&ch=1&di=0&device=[{"id":"a","va":"Lamp-00"}]
```

Sets the name of the group 0 for the channel 1.

```
/api/v100/dali_devices.ssi?action=set_device&ch=1&gi=0&device=[{"id":"na%22,%22va%22:%22Group-00%22}]
```

Sets the actual light intensity to 100% for the lamp 0 of the channel 1.

```
/api/v100/dali_devices.ssi?action=set_device&ch=1&di=0&device=[{"id":"val%22,%22va%22:%22100%22}]
```

12.2.5 Get groups

Allows retrieving the information of the groups.

12.2.5.1 Request URL

```
/api/v100/dali_devices.ssi?action=get_groups&ch={channel}
```

12.2.5.2 Parameters

Name	Value
action	get_groups
ch	The number of the DALI channel, 1-4

12.2.5.3 Response

The response contains the values as well as other information like the values limitation, names, etc.

```
{
  "type": "dali_devices",
  "action": "get_groups",
  "data": {
    "status": 0,
    "devices": {
      "devices": [{
        "ii": "0",
        "na": "Lamp 1-00",
        "fl": 1,
        "gr": 1
      }, {
        "ii": "1",
        "na": "Lamp 1-01",
        "fl": 1,
        "gr": 2
      }, {
        "ii": "2",
        "na": "Lamp 1-02",
        "fl": 1,
        "gr": 4
      }, {
        "ii": "3",
```

```
"na": "Lamp 1-03",
"fl": 1,
"gr": 7
}],
"groups": [{
  "ii": "-1",
  "na": "Channel 1",
  "fl": 0,
  "al": 76,
  "si": 4
}, {
  "ii": "0",
  "na": "Group 1-00",
  "fl": 0,
  "al": 50,
  "si": 4
}, {
  "ii": "1",
  "na": "Group 1-01",
  "fl": 0,
  "al": 100,
  "si": 4
}, {
  "ii": "2",
  "na": "Group 1-02",
  "fl": 0,
  "al": 100,
  "si": 4
}, {
  "ii": "3",
  "na": "Group 1-03",
  "fl": 0,
  "al": 0,
  "si": 0
}, {
  "ii": "4",
  "na": "Group 1-04",
  "fl": 0,
  "al": 0,
  "si": 0
}, {
  "ii": "5",
  "na": "Group 1-05",
  "fl": 0,
  "al": 0,
  "si": 0
}
```

```
}, {
  "ii": "6",
  "na": "Group 1-06",
  "fl": 0,
  "al": 0,
  "si": 0
}, {
  "ii": "7",
  "na": "Group 1-07",
  "fl": 0,
  "al": 0,
  "si": 0
}, {
  "ii": "8",
  "na": "Group 1-08",
  "fl": 0,
  "al": 0,
  "si": 0
}, {
  "ii": "9",
  "na": "Group 1-09",
  "fl": 0,
  "al": 0,
  "si": 0
}, {
  "ii": "10",
  "na": "Group 1-10",
  "fl": 0,
  "al": 0,
  "si": 0
}, {
  "ii": "11",
  "na": "Group 1-11",
  "fl": 0,
  "al": 0,
  "si": 0
}, {
  "ii": "12",
  "na": "Group 1-12",
  "fl": 0,
  "al": 0,
  "si": 0
}, {
  "ii": "13",
  "na": "Group 1-13",
  "fl": 0,
```



```

    "al": 0,
    "si": 0
  }, {
    "ii": "14",
    "na": "Group 1-14",
    "fl": 0,
    "al": 0,
    "si": 0
  }, {
    "ii": "15",
    "na": "Group 1-15",
    "fl": 0,
    "al": 0,
    "si": 0
  }
]
}
}
}

```

12.2.5.3.1 action

get_groups

12.2.5.3.2 data

Contains the information of the DALI groups.

12.2.5.3.3 devices

The list of assigned devices.

12.2.5.3.3.1 ii

The lamp index, 0-63.

12.2.5.3.3.2 na

The name of the lamp.

12.2.5.3.3.3 fl

The flags of the lamp.

Value	Description
0	No lamp assigned for this index
1	A lamp is assigned for this index

12.2.5.3.3.4 gr

It represents the DALI variables "GROUP_0_8" and "GROUP_9_15" concatenated in a 16 bit.

12.2.5.3.4 groups

The list of groups.

12.2.5.3.4.1 ii

The group index, 0-15 and -1 for the channel broadcast.

12.2.5.3.4.2 na

The name of the group.

12.2.5.3.4.3 fl

The flags of the group.

12.2.5.3.4.4 al

The actual light intensity of the group in percent multiplied by 10. For example; 0 = 0%, 1 = 0.1%, 1000 = 100%.

12.2.5.3.4.5 si

The actual status information of the group.

12.2.5.4 Examples

Gets the groups for the channel 1.

```
/api/v100/dali_devices.ssi?action=get_groups&ch=1
```

12.2.6 Get scenes

Allows retrieving the information of the scenes.

12.2.6.1 Request URL

```
/api/v100/dali_devices.ssi?action=get_scenes&ch={channel}
```

12.2.6.2 Parameters

Name	Value
------	-------

action	get_scenes
--------	------------

ch	The number of the DALI channel, 1-4
----	-------------------------------------

12.2.6.3 Response

The response contains the scenes values for each assigned lamps as well as other information about the lamps like their names.

```
{
  "type": "dali_devices",
  "action": "get_scenes",
  "data": {
    "status": 0,
    "devices": {
      "devices": [{
        "ii": "0",
        "na": "Lamp 1-00",
        "fl": 1,
```

```

    "sn": [1000, 100, -1, -1, -1, -1, -1, -1, -1, -1, -1, -1, -1, -1, -1, -1]
  }, {
    "ii": "1",
    "na": "Lamp 1-01",
    "fl": 1,
    "sn": [1000, 100, -1, -1, -1, -1, -1, -1, -1, -1, -1, -1, -1, -1, -1, -1]
  }, {
    "ii": "2",
    "na": "Lamp 1-02",
    "fl": 1,
    "sn": [1000, 100, -1, -1, -1, -1, -1, -1, -1, -1, -1, -1, -1, -1, -1, -1]
  }, {
    "ii": "3",
    "na": "Lamp 1-03",
    "fl": 1,
    "sn": [1000, 100, -1, -1, -1, -1, -1, -1, -1, -1, -1, -1, -1, -1, -1, -1]
  }
]
}
}
}

```

12.2.6.3.1 action

get_scenes

12.2.6.3.2 data

Contains the DALI scenes information.

12.2.6.3.3 devices

The list of assigned devices.

12.2.6.3.3.1 ii

The lamp index, 0-63.

12.2.6.3.3.2 na

The name of the lamp.

12.2.6.3.3.3 fl

The flags of the lamp.

Value	Description
0	No lamp assigned for this index
1	A lamp is assigned for this index

12.2.6.3.3.4 sn

An array of the values for the 16 scenes. The light intensity of each scene in percent multiplied by 10. For example; 0 = 0%, 1 = 0.1%, 1000 = 100%.

12.2.6.4 Examples

Gets the scenes for the channel 1.

```
/api/v100/dali_devices.ssi?action=get_scenes&ch=1
```

12.2.7 Set scenes

Allows modifying the scenes.

12.2.7.1 Request URL

```
/api/v100/dali_devices.ssi?action=set_scenes&ch={channel}&devices={data}
```

12.2.7.2 Parameters

Name	Value
action	set_scenes
ch	The number of the DALI channel, 1-4
devices	The scene data for each lamp

12.2.7.2.1 devices

Contains the scene values for each assigned lamp.

```
{
  "devices": [{
    "ii": "0",
    "sn": [1000, 100, -1, -1, -1, -1, -1, -1, -1, -1, -1, -1, -1, -1, -1, -1]
  }, {
    "ii": "1",
    "sn": [1000, 100, -1, -1, -1, -1, -1, -1, -1, -1, -1, -1, -1, -1, -1, -1]
  }, {
    "ii": "2",
    "sn": [1000, 100, -1, -1, -1, -1, -1, -1, -1, -1, -1, -1, -1, -1, -1, -1]
  }, {
    "ii": "3",
    "sn": [1000, 100, -1, -1, -1, -1, -1, -1, -1, -1, -1, -1, -1, -1, -1, -1]
  }
  ]
}
```

12.2.7.2.1.1 ii

The lamp index, 0-63.

12.2.7.2.1.2 sn

An array of the values for the 16 scenes. The light intensity of each scene in percent multiplied by 10. For example; 0 = 0%, 1 = 0.1%, 1000 = 100%. A value of -1 represents DALI MASK.

12.2.7.3 Examples

Sets the scenes for the channel 1.

```

/api/v100/dali_devices.ssi?action=set_scenes&ch=1&devices=%7B%22devices%22%3A%5B%7B%22ii%22%3A%220%22%2C%22na%22%3A%22Lamp-00%22%2C%22fl%22%3A1%2C%22sn%22%3A%5B1000%2C100%2C-1%2C-1%2C-1%2C-1%2C-1%2C-1%2C-1%2C-1%2C-1%2C-1%2C-1%2C-1%2C-1%2C-1%2C-1%2C-1%2C-1%2C-1%2C-1%2C-1%2C%7D%2C%7B%22ii%22%3A%221%22%2C%22na%22%3A%22Lamp%201-01%22%2C%22fl%22%3A1%2C%22sn%22%3A%5B1000%2C100%2C-1%2C-1%2C-1%2C-1%2C-1%2C-1%2C-1%2C-1%2C-1%2C-1%2C-1%2C-1%2C-1%2C-1%2C-1%2C-1%2C-1%2C-1%2C-1%2C%7D%2C%7B%22ii%22%3A%222%22%2C%22na%22%3A%22Lamp%201-02%22%2C%22fl%22%3A1%2C%22sn%22%3A%5B1000%2C100%2C-1%2C-1%2C-1%2C-1%2C-1%2C-1%2C-1%2C-1%2C-1%2C-1%2C-1%2C-1%2C-1%2C-1%2C-1%2C-1%2C-1%2C-1%2C-1%2C%7D%2C%7B%22ii%22%3A%223%22%2C%22na%22%3A%22Lamp%201-03%22%2C%22fl%22%3A1%2C%22sn%22%3A%5B1000%2C100%2C-1%2C-1%2C-1%2C-1%2C-1%2C-1%2C-1%2C-1%2C-1%2C-1%2C-1%2C-1%2C-1%2C-1%2C-1%2C-1%2C-1%2C-1%2C-1%2C-1%2C%7D%5D%7D

```

12.2.8 Recall, store and delete scenes for groups or channel

Recall, store and delete scenes with this request.

12.2.8.1 Request URL

```

/api/v100/dali_devices.ssi?action=recall_scene&ch={channel}&gi={group-index}&si={scene-index}

```

12.2.8.2 Parameters

Name	Value
action	recall_scene, store_scene or delete_scene
ch	The number of the DALI channel, 1-4
gi	The DALI group, 0-15 or -1 for the broadcast. Multiple groups can be passed in an array [gi, gi, ...]. The array must be URL encoded.
si	The index of the DALI scene, 0-15

12.2.8.3 Examples

Recalls the scene 2 for the group 10 on the channel 1.

```

/api/v100/dali_devices.ssi?action=recall_scene&ch=1&gi=10&si=2

```

Stores the scene 2 for the group 10 on the channel 1.

```

/api/v100/dali_devices.ssi?action=store_scene&ch=1&gi=10&si=2

```

Deletes the scene 2 for the group 10 on the channel 1.

```

/api/v100/dali_devices.ssi?action=delete_scene&ch=1&gi=10&si=2

```

12.2.9 Set lamp, group or channel DT8 colour

Allows modifying the colour of a lamp or multiple lamps of the DALI type 8.

This request uses the DALI short address of the lamp. The short address of a lamp index can be retrieved with the request get or get_device.

12.2.9.1 Request URL

```
/api/v100/dali_devices.ssi?action=set_colour&ch={channel}&sa={short-address}&cid={colour-id}&ctype={colour-type}&cvalue={colour-value}
```

12.2.9.2 Parameters

Name	Value
action	set_colour
ch	The number of the DALI channel, 1-4
sa	The DALI short address, 0-63. The addresses must be passed in an array [sa, sa, ...]. The array must be URL encoded.
gi	The DALI group, 0-15 or -1 for the broadcast. The groups must be passed in an array [gi, gi, ...]. The array must be URL encoded.
cid	The colour to modify
ctype	The type of colour
cvalue	The colour value

12.2.9.2.1 cid

Indicates the colour to modify.

Value	Description
d8ac	Actual Level
d8tp	Power On Level
d8tf	System Failure Level
d8s0	Scene 0
d8s1	Scene 1
d8s2	Scene 2
d8s3	Scene 3
d8s4	Scene 4
d8s5	Scene 5
d8s6	Scene 6
d8s7	Scene 7
d8s8	Scene 8
d8s9	Scene 9
d8s10	Scene 10
d8s11	Scene 11
d8s12	Scene 12
d8s13	Scene 13
d8s14	Scene 14
d8s15	Scene 15
d8tw	Warmest Tc
d8tc	Coolest Tc

12.2.9.2.2 ctype

Indicates the type of colour.

Value	Description
16	xy-coordinate
32	colour temperature Tc
64	primary N
128	RGBWAF

12.2.9.2.3 cvalue

Indicates the value of the colour. This value is in the JSON format and it must be URL encoded.

```
{
  "11": 900,
  "xx": 400,
```

```

"xy": 65535,
"tc": 333,
"p0": 400,
"p1": 65535,
"p2": 65535,
"p3": 65535,
"p4": 65535,
"p5": 65535,
"rr": 144,
"rg": 1,
"rb": 255,
"rw": 255,
"ra": 255,
"rf": 255,
"ll_isMask": false,
"xx_isMask": false,
"xy_isMask": true,
"tc_isMask": false,
"p0_isMask": false,
"p1_isMask": true,
"p2_isMask": true,
"p3_isMask": true,
"p4_isMask": true,
"p5_isMask": true,
"rr_isMask": false,
"rg_isMask": false,
"rb_isMask": true,
"rw_isMask": true,
"ra_isMask": true,
"rf_isMask": true
}

```

12.2.9.2.3.1 ll

The level of light intensity in percent multiplied by 10. For example; 0 = 0%, 1 = 0.1%, 1000 = 100%.

12.2.9.2.3.2 xx

The x, 0-65535, value for the type *xy-coordinate*.

12.2.9.2.3.3 xy

The y, 0-65535, value for the type *xy-coordinate*.

12.2.9.2.3.4 tc

The value, 0-65535, for the type *colour temperature Tc*. The unit of the value is Mirek. To value is given by the formula;

$$M = 1\,000\,000 / T,$$

where M is the Mirek value, T is the colour temperature in Kelvin.

12.2.9.2.3.5 p0, p1, p2, p3, p4, p5

The value, 0-65535, of the level 0, 1, 2, 3, 4 or 5 for the type *primary N*.

12.2.9.2.3.6 rr

The value, 0-255, of the red level for the type *RGBWAF*.

12.2.9.2.3.7 rg

The value, 0-255, of the green level for the type *RGBWAF*.

12.2.9.2.3.8 rb

The value, 0-255, of the blue level for the type *RGBWAF*.

12.2.9.2.3.9 rw

The value, 0-255, of the white level for the type *RGBWAF*.

12.2.9.2.3.10 ra

The value, 0-255, of the amber level for the type *RGBWAF*.

12.2.9.2.3.11 rf

The value, 0-255, of the freecolour level for the type *RGBWAF*.

12.2.9.2.3.12 xx_isMask

Indicates that the associated value is the DALI MASK value.

12.2.9.3 Examples

Sets to 4000 Kelvin the groups 1 on the channel 1.

```
/api/v100/dali_devices.ssi?&action=set_colour&ch=1&sa=%5B%5D&cid=d8ac&ctype=32&cvalue=%7B%2211%22%3A921%2C%22xx%22%3A250%2C%22xy%22%3A65535%2C%22tc%22%3A250%2C%22p0%22%3A250%2C%22p1%22%3A65535%2C%22p2%22%3A65535%2C%22p3%22%3A65535%2C%22p4%22%3A65535%2C%22p5%22%3A65535%2C%22rr%22%3A250%2C%22rg%22%3A0%2C%22rb%22%3A255%2C%22rw%22%3A255%2C%22ra%22%3A255%2C%22rf%22%3A255%2C%2211_isMask%22%3Afalse%2C%22xx_isMask%22%3Afalse%2C%22xy_isMask%22%3Atrue%2C%22tc_isMask%22%3Afalse%2C%22p0_isMask%22%3Afalse%2C%22p1_isMask%22%3Atrue%2C%22p2_isMask%22%3Atrue%2C%22p3_isMask%22%3Atrue%2C%22p4_isMask%22%3Atrue%2C%22p5_isMask%22%3Atrue%2C%22rr_isMask%22%3Afalse%2C%22rg_isMask%22%3Afalse%2C%22rb_isMask%22%3Atrue%2C%22rw_isMask%22%3Atrue%2C%22ra_isMask%22%3Atrue%2C%22rf_isMask%22%3Atrue%7D
```